

# **BORGWARNER**

**On the hunt for thesis work?**

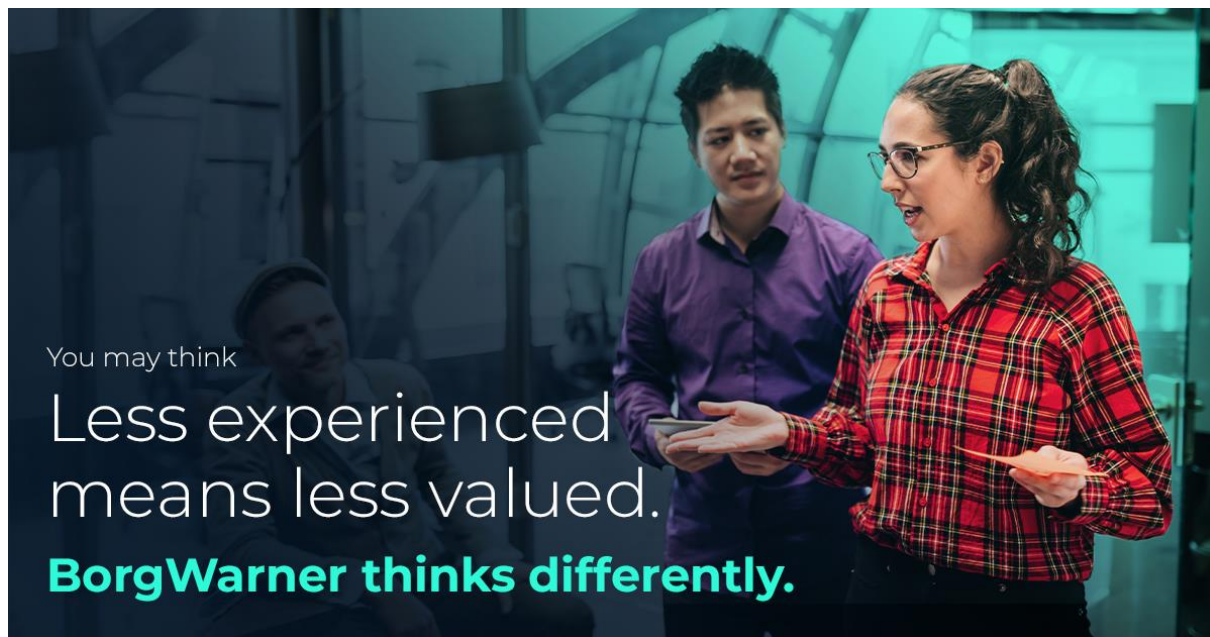

BorgWarner i Landskrona utvecklar och tillverkar system och komponenter till de största fordonstillverkarna världen över. Vår vision och mål och är att utveckla rena och energi-effektiva system för framdrivning av förbrännings-, hybrid- och elektriska fordon.

BorgWarner in Landskrona develops and manufacture systems and components to the largest vehicle manufacturers in the world. Our vision and goal is to develop clean and energy-efficient systems for propulsion of combustion, hybrid and electric vehicles.

**Content**

---

Software Verification – How can AI be used in software testing? ..... 4

Development of a Temperature Estimation model ..... 5

Simulation model of a BLDC motor..... 6

Continuous Integration – Report Aggregation ..... 7

How to gain insight and react quicker with improved manufacturing data analysis ..... 8

Improvement of operator training and thus less waste in manufacturing operations ..... 9

Modeling of Gear-Box Oil Temperature..... 10

Model-Based Control of Driveline Oscillations in an EV ..... 11

Driver Model ..... 12

Development of a redundant motor speed signal ..... 13

Development of a current estimation model ..... 14

Project visualization using CI/CD ..... 16

Cyber Security together with CI/CD ..... 17

Are you interested in thesis work within another area?..... 18

# Software Verification – How can AI be used in software testing?

---

## Background

In the software verification area, there is a lot of requirements and corresponding testcases.

How can we use AI to optimize what to verify and maximize the quality in the build.

Some testcases can be unstable due to timing requirements that our test benches not always can meet and thereby give false result. In those cases, would it be possible for an AI for detecting if a run of an unstable testcase resulted in valid result or if the test should be rerun instead of a tester having to make that decision.



Today we base what to verify on experience and what area changed. The high level of automated testcases makes this a complex task. Can AI help create test suite based on results from nightly runs, the changed functionality?

## Challenge

- Is it possible to see patterns in the result
- How can AI be beneficial in this area
- What metadata for the build and from test environment to make test suite suggestions
- What is the draw back
- Is it possible to use an AI to suggest a custom test suit for a nightly run to maximize our test benches.

The work will preferably be conducted at BorgWarner in Landskrona and is suitable for 1-2 persons.

Knowledge of AI is required.

## Reporting

The master thesis shall be reported as a written report, a complete test environment and an oral presentation at BorgWarner.

## Contact

**Måns Andersson**

Manager Test System

+46724548419

mandersson@borgwarner.com

# Development of a Temperature Estimation model

---

## Background

BorgWarner is an automotive supplier developing clean and efficient technology solutions for hybrid, electric and combustion vehicles. At the site in Landskrona, driveline and propulsion systems are developed and produced for manufacturers around the world.

For some of the products developed by BorgWarner, the performance depends on the temperatures of the components and the oil. Since not all temperatures can be measured, it is important to accurately estimate the needed temperatures from available measurements. The purpose of this thesis is to update the existing model to better estimate temperatures in newer products. This includes analyzing temperature development in different parts of the system and from this implementing an estimation model for the temperatures.



## Tasks

- Investigate approaches to model thermal dynamics in Wet Lamella Clutches.
- Examine the performance of the current thermal model, and either suggest possibilities to improve parameter tuning of the current model, or suggest a new model with improved estimation accuracy.
- Implement above strategies in MATLAB Simulink, and compare the estimation accuracy to the current thermal model.

The master thesis shall be performed at BorgWarner, Landskrona. We prefer that two students write the thesis together. Students will get compensation for completed master thesis, and lunch will be paid by BorgWarner.

Prerequisites: Control Theory, System Identification and/or Machine Learning, MATLAB Simulink.

## Result

The thesis outcome should be a written report, simulation models, implementation of the strategies and an oral presentation at BorgWarner.

## Contact

**Meike Rönn**  
DTS – ETC Coupling Dynamics & Controls  
+46 70 826 3982  
mronn@borgwarner.com

**Arne Hörberg**  
DTS – ETC Coupling Dynamics & Controls  
+46 76 128 2674  
ahorberg@borgwarner.com

# Simulation model of a BLDC motor

---

## Background

BorgWarner is an automotive supplier developing clean and efficient technology solutions for hybrid, electric and combustion vehicles. At the site in Landskrona, driveline and propulsion systems are developed and produced for manufacturers around the world.

BorgWarner Landskrona has several applications of actuators using a Brushless DC, permanent magnet (BLDC) motor in different actuators. In order to improve development and testing of control strategies, the objective of this thesis is to develop a way to estimate motor parameters from measured data for a model of a BLDC motor.



## Tasks

- Investigate approaches to estimate the motor parameters from measured data.
- Implement at least one estimation approach.
- Collect measurements on a BLDC motor to verify the approach.

The master thesis shall be performed at BorgWarner, Landskrona. We prefer that two students write the thesis together. Students will get a compensation for completed master thesis, and lunch will be paid by BorgWarner.

Prerequisites: MATLAB Simulink, System Identification

## Result

The thesis outcome should be a written report, implemented simulation model, implemented method for estimation of motor parameters and an oral presentation at BorgWarner.

## Contact

### Meike Rönn

DTS - ETC Coupling Dynamics & Controls  
+4670 826 3982  
mronn@borgwarner.com

# Continuous Integration – Report Aggregation

---

## Background

A continuous integration system consists of many pipelines that produces various documents and reports. Data from different sources needs to be collected to be able to display project metrics and progress.



## Challenge

- Examine and understand the needs
- Do a market analysis of available tools
- Propose tools that fulfills the needs
- Create a demo implementation based on BorgWarner pipelines and proposed tools.

The work will preferably be conducted at BorgWarner in Landskrona and is suitable for 1-2 persons.

Knowledge of CI/CD or Jenkins is preferred.

## Result

The master thesis shall be reported as a written report, a demo implementation, and an oral presentation at BorgWarner.

## Contact

**Patrik Östman**  
Software Architect  
+46418476778  
postman@borgwarner.com

# How to gain insight and react quicker with improved manufacturing data analysis

---

## Background

Manufacturing operations are getting more complex, digitalized, and connected. Areas such as Industry 4.0, Smart Factory, Autonomous systems, AI, IoT, Machine learning are getting more interesting for factories to investigate further and with this, a larger amount of process data is logged in databases. In order to gain deeper insights and be able to react quicker on potential deviations, thus reduce waste, there are great potential in working with data analysis and visualization. In the next step user-friendly applications can facilitate this handling to be able to visualize and support with analysis on specific areas of interest. When negative trends are observed, pre-determined actions be triggered which will foster a more proactive mindset instead of reacting after deviations occur. We therefore seek master thesis students that want to investigate potential areas to improve withing above areas.



## Challenge

- Investigate how data analysis, visualization and usage can improve to foster a more proactive approach to problem solving in manufacturing operations.
- Benchmark other industries, factories and companies to find best practice
- How can AI, machine learning and other areas be implemented/used to improve data analysis?
- Build a programmed model/application based on the outcome of point above to demonstrate result by using at least one real life failure mode in BorgWarner manufacturing operations

The work will be conducted at BorgWarner in Landskrona.

## Reporting

The thesis outcome should be a written report, demonstration model and an oral presentation at BorgWarner.

## Contact

**Pontus Johansson**  
Manufacturing Engineering & Maintenance  
Supervisor

pjohansson@borgwarner.com  
+46 728 898 653



# Improvement of operator training and thus less waste in manufacturing operations

---

## Background

At BorgWarner we would like to teach and train the production personnel in the best way possible regardless of previous experience. Each person that begins his/her working journey at BorgWarner is taught differently, much depending on the trainer and the training material and/or methods. We humans are individuals that acquire knowledge differently, this is something we cannot change but we would like to enhance the channels to enable excellence knowledge learning.



In production, above is primarily focusing on operator training on work instructions and tasks. If not done standardized the risk of deviations, rejects and other waste. Hence, we seek students that are interested in manufacturing operations, standardized work and willing to deep dive into the subject of learning/training.

## Challenge

- Decrease the learning curve for new employees.
  - Analysis cognitive learning theory, what type of methods can be used?
- Increase the quality assurance, especially visual requirements.
  - Combine practical & theoretical exercises.
- Is it possible to use the same structure throughout the whole production-line?
- How do we know when a person is trained and ready?
- Study human behavior and cognitive learning with data analysis to base the decision in the training pattern.
- Benchmark other industries/factories/companies for best practice
- Create a demo/proposal of how to integrate the material into system support to improve usability and ensure compliance.

The work will preferably be conducted at BorgWarner in Landskrona and is suitable for 1-2 persons.

## Reporting

The thesis outcome should be a written report, a complete setup of training material, a demo/proposal of system integration and an oral presentation at BorgWarner

## Contact

**Pontus Johansson**

Manufacturing Engineering & Maintenance Supervisor

Pjohansson@borgwarner.com

+46 728 898 653

# Modeling of Gear-Box Oil Temperature

---

## Background

BorgWarner is an automotive supplier developing clean and efficient technology solutions for hybrid, electric and combustion vehicles.

At the site in Landskrona, driveline and propulsion systems are developed and produced for manufacturers around the world.

In order to achieve high torque accuracy on the gear-box output shaft, and also protect the gear box from overheating, it is necessary for the driveline control system to have an accurate estimate of the gear-box oil temperature.



## Thesis Assignments

- Conduct a literature study to determine the model complexity suitable for real-time computation.
- Implement the selected thermal model in MATLAB/Simulink.
- Use/develop a mathematical optimization/ System identification method to determine model-parameter values.
- Validate the model accuracy against collected temperature data.



## Results

The master thesis shall be reported as a written report and an oral presentation at BorgWarner in Landskrona.

## Contact

**Gabriel Turesson**  
ETC, PDS Controls  
gturesson@borgwarner.com  
+46 728898544

# Model-Based Control of Driveline Oscillations in an EV

## Background

BorgWarner is an automotive supplier developing clean and efficient technology solutions for hybrid, electric and combustion vehicles.

At the site in Landskrona, driveline and propulsion systems are developed and produced for manufacturers around the world.

The fast torque response achievable with electric machines has enabled active-damping torque control to reduce drive-line speed oscillations (jerk). With this type of control, oscillations in the frequency range that would create discomfort for the driver can be reduced greatly.

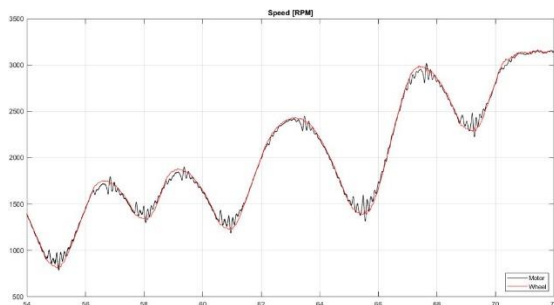

*Example of driveline oscillations in a vehicle.*

*BorgWarner is an automotive supplier developing clean and efficient technology solutions for hybrid, electric and combustion vehicles.*

## Thesis Assignments

- Develop a drive-line model suitable for controller design.
- Compare a model-based state-feedback controller design with conventional PID control.
- Design a controller to be robust against model uncertainties and system delays.
- Integrate the controller into existing inverter software using TargetLink for real-time verification in test vehicle.

## Results

The master thesis shall be reported as a written report and an oral presentation at BorgWarner in Landskrona.

## Contact

**Gabriel Turesson**  
ETC, PDS Controls  
gturesson@borgwarner.com  
+46 728898544

**Robin Levenhammar**  
ETC, PDS Controls  
rlevenhammar@borgwarner.com  
+46 728898664

# Driver Model

---

## Background

At BorgWarner we have a vehicle model that aims to simulate the vehicle dynamics of a real car.

It includes models of chassis, wheel suspension, tire, and drivetrain. There are different roads and tracks which can have slope and banking.

The vehicle model is currently controlled by a fairly simple driver model which are able to drive around a track but is not able push the car to the limit to e.g. set a good lap time.

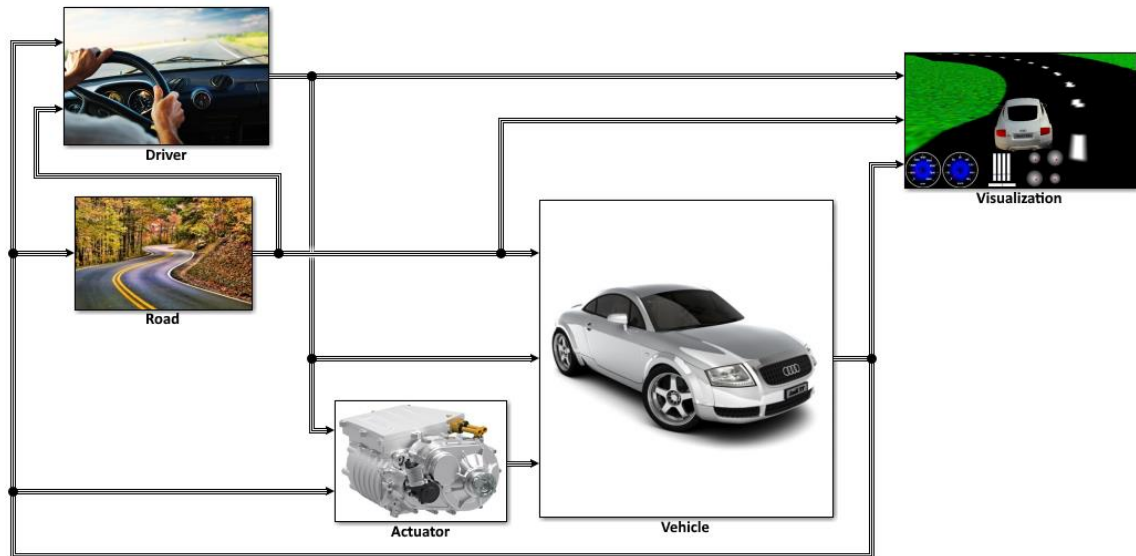

*Vehicle model in Simulink*

## Thesis Assignments

- Develop a controller that are able drive the vehicle model to its limits to e.g. set a good lap time.
- Evaluate if an “AI driver” that is based on a neural network is preferred instead of a conventional controller.
- The driver model should run in Simulink.

## Results

The master thesis shall be reported as a written report and an oral presentation at BorgWarner in Landskrona.

## Contact

**Pierre Petterson**  
ETC, PDS Controls  
ppettersson@borgwarner.com  
+46 76 506 35 14

# Development of a redundant motor speed signal

---

## Background

BorgWarner is an automotive supplier developing clean and efficient technology solutions for hybrid, electric and combustion vehicles. At the site in Landskrona, driveline and propulsion systems are developed and produced for manufacturers around the world.

The BorgWarner coupling transfers torque between two axles in the vehicle. The torque transfer can be between the front and rear axle as in the conventional all-wheel drive vehicles or between the left and right wheel as a differential brake. A foundational feature in the coupling is the control of a pump motor which produces a hydraulic pressure that in turn generates the transferred torque. The speed of the pump motor is essential for the overall control of the coupling torque and important for validating that the product works as intended. In some applications the monitoring of the motor speed is safety critical, meaning that special arrangements are necessary to guarantee its validity.



For such applications the computation of the motor speed must be validated by another algorithm that derives a redundant motor speed entirely decoupled for the normal motor speed. Then the two signals have to be compared with each other and a decision whether the motor speed is reliable or not shall be taken.

## Tasks

- Examine the present way of deriving the motor speed of the BorgWarner BLDC pump motor.
- Propose a redundant way to derive the motor speed that differs from the existing one.
- Propose ways to compare the two different motor speed signals to judge whether the signal is reliable.
- Measure the extra CPU load due to the added functionality.

The master thesis shall be performed at BorgWarner, Landskrona. We prefer that two students write the thesis together.

Prerequisites: Control Theory, Signal processing, C-programming, Embedded software, and MATLAB Simulink.

## Result

The thesis outcome should be a written report, simulation models, c-code implementation, and an oral presentation at BorgWarner.

## Contact

**Jacob Svendenius**  
DBS – ETC HomeRoom Software – Core  
Software  
+46 72 552 53 84  
jsvendenius@borgwarner.com

**Bertil Ströberg**  
DBS – ETC HomeRoom Software – Core  
Software  
+46 72 889 85 16  
bstroberg-ext@borgwarner.com

# Development of a current estimation model

## Background

BorgWarner is an automotive supplier developing clean and efficient technology solutions for hybrid, electric and combustion vehicles. At the site in Landskrona, driveline and propulsion systems are developed and produced for manufacturers around the world.

For some of the products developed by BorgWarner, the performance depends on the temperatures of the components and the oil. There is a trend in car industry to move from melt fuses to electrical fuses which requires supply current to be measured with higher accuracy to support our current limitation. The current sensor is placed to measure motor current which is not the same as the supply current. Therefore, we need a model to accurately estimate supply current based on measured motor current.



The purpose of this thesis is to update the existing model to better estimate supply current in newer products. This includes analyzing sampling methods, rpm, torque and temperature dependencies and from this implementing an estimation model for the supply current.

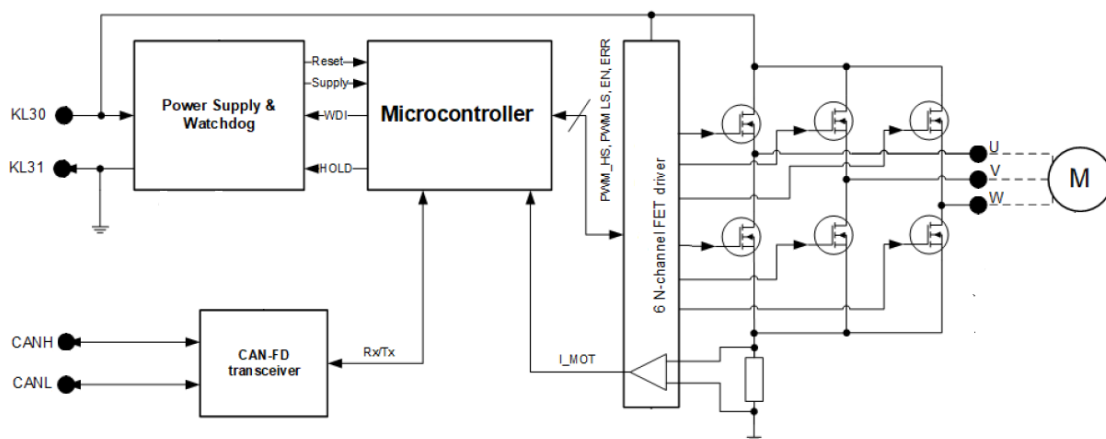

## Tasks

- Investigate approaches to model motor current to supply current translation.
- Examine the performance of the current model, and either suggest possibilities to improve parameter tuning of the current model or suggest a new model with improved estimation accuracy.
- Implement above in software and do comparison between estimation and measurement.

The master thesis shall be performed at BorgWarner, Landskrona. We prefer that two students write the thesis together.

Prerequisites: Signal processing, measurement, embedded programming, and electronic hardware.

## Result

The thesis outcome should be a written report, code implementation and an oral presentation at BorgWarner.

## Contact

### **Per Söderberg**

DBS – ETC HomeRoom eTMS - Mechanics  
+46 728 898 658  
psoderberg@borgwarner.com

### **Jacob Svendenius**

DBS – ETC HomeRoom Software – Core Software  
+46 72 552 53 84  
jsvendenius@borgwarner.com

# Project visualization using CI/CD

---

## Background

In today's complex and dynamic business environment, it is more important than ever to be able to effectively visualize the status of projects. This is because projects are often large and complex, with multiple stakeholders involved. Without effective visualization, it can be difficult to keep track of all of the tasks and to identify potential problems early on.

CI/CD can be used to automate the generation of project visualizations, which can save project managers time and effort. It can also help to ensure that the visualizations are always up-to-date and accurate.

## Challenges

- Find good ways to collect and utilize data from projects.
- Define effective ways to visualize the status of different types of projects.
- Propose solutions to use machine learning to improve the accuracy and efficiency of project visualization.
- Propose solutions to use project visualization to identify and address problems early in the project lifecycle.
- Create a demo using CI/CD and evaluate the solutions.

The work will preferably be conducted at BorgWarner in Landskrona and is suitable for 1-2 persons.

## Reporting

The thesis outcome should be a written report, demonstration model and an oral presentation at BorgWarner.

## Contact

**Henrik Nilsson**

Manager Infrastructure and simulations

+46 72-889 85 53

hnilsson@borgwarner.com



# Cyber Security together with CI/CD

---

## Background

The rapidly growing connectivity of vehicles enables lots of new functionality. At the same time, this functionality opens potential risk for cyber-attacks on vehicles. Such attacks threaten the functional safety of the vehicle and could cause financial damage or even worse personal injuries.

That is why Cyber Security is so important today and that all the software in a vehicle is maintained throughout the complete vehicle life cycle. To be able to support this in a quick and effective way, the software release work needs to be automated. This is done via CI/CD in our Software Factory.

## Challenges

- Research the market to find good ways to work with Cyber Security together with CI/CD.
- Define and validate how to work with Cyber Security data in a secure way.
- Find weak spots regarding Cyber Security in our Software Factory.
- Propose improvements for Cyber Security in our Software Factory.
- Implement some of the proposed improvements in our Software Factory.

The work will preferably be conducted at BorgWarner in Landskrona and is suitable for 1-2 people.

## Reporting

The thesis outcome should be a written report, a demonstration of implemented improvements and an oral presentation at BorgWarner.

## Contact

### Henrik Nilsson

Manager Infrastructure and simulations

+46 72-889 85 53

hnilsson@borgwarner.com

## Are you interested in thesis work within another area?

---

We can also offer master thesis work for product development or similar within the following areas:

- Active suspension
- Torque management systems for (eTMS) for wind- and/or waterpower
- eLSD for heavy vehicles and trucks
- Torque vectoring applications for agriculture machinery
- Torque vectoring for trailer stability
- Power take-offs for e-trucks
- Torque management to reduce tire wear and particle emissions

A master thesis within these areas includes a theoretical study of the product or new concept, including a literature search. You also investigate what requirements of the product would be needed. You may also prepare for physical testing or simulation; in some cases, testing or simulations may also be possible.

Send your application with CV and personal letter to Louise Gren, [lgren@borgwarner.com](mailto:lgren@borgwarner.com)

For thesis work within other areas such as production technology, logistics, purchasing, marketing, business development and quality.

Send your application with CV and personal letter to Inez Kjellman from HR, [ikjellman@borgwarner.com](mailto:ikjellman@borgwarner.com) with a description of your ideas.

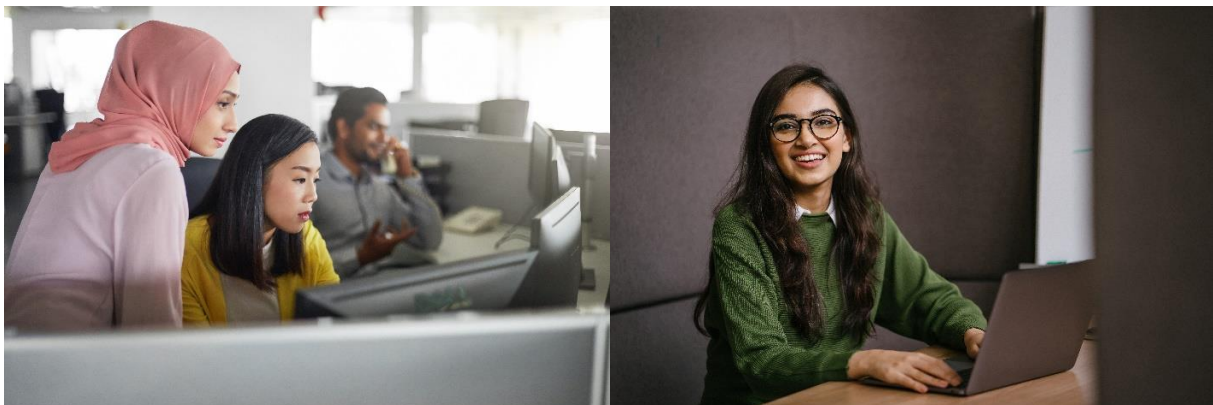

## **BorgWarner Sweden AB**

**Reception:**

0418-47 65 00

**Address:**

Instrumentgatan 15  
261 24 Landskrona

**Recruitment contact:**

Inez Kjellman

**[ikjellman@borgwarner.com](mailto:ikjellman@borgwarner.com)**