

On/Off Fan Drive Diagnostic and Service Guide

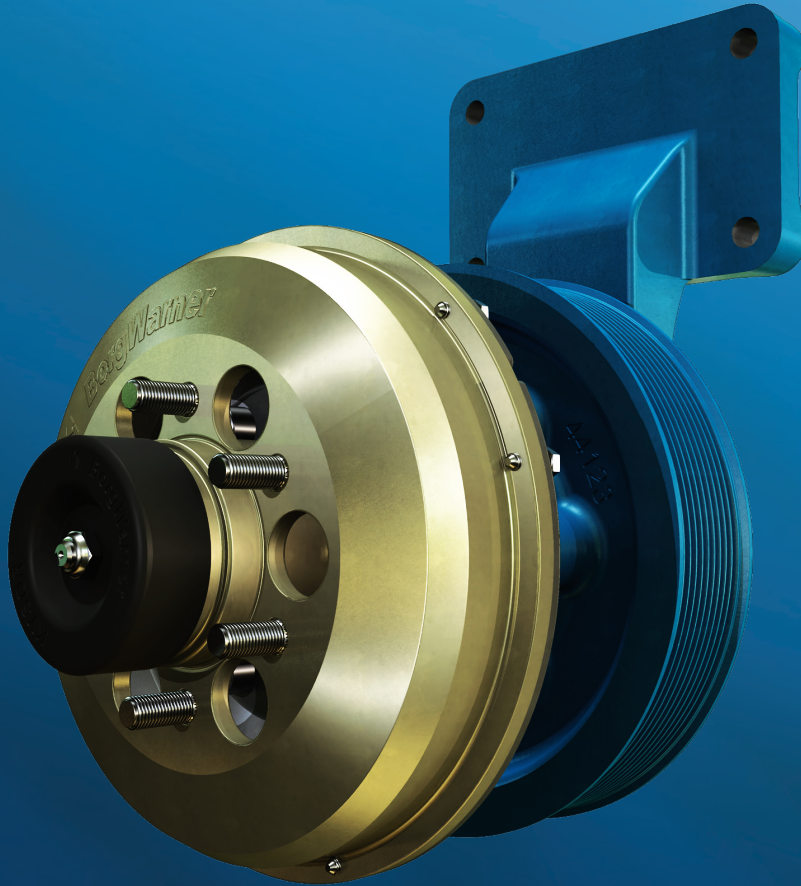

Index

Additional Support / Recommended Practices	Page 3
Components of the Fan Drive	Page 4
Components of the Clutch Assembly	Page 5
Housing Cover (Only On 1090-09900-01xx)	Page 6
Repair Kit and Replacement Guide	Page 7-14
Removal of the Clutch Assembly	Page 15
Inspecting the Pulley (Hub) Assembly for Play	Page 16
Inspecting the Clutch Assembly for Play	Page 17
Checking the Remaining Liner Life On/Off	Page 18
Checking the Remaining Liner Life DuroSpeed™	Page 19
Troubleshoot:	
Clutch Will Not Engage	Page 20
Fan Drive Has Air Leak	Page 21
Clutch Will Not Disengage	Page 22
Fan Drive Has Play	Page 23
Clutch Failure Modes and Warranty Coverage	Page 24
Air System Contamination	Page 25
Control System Issue	Page 26
Control System Issue (Root Causes)	Page 27
Evidence of Pulley Bearing Failure	Page 28
Improper Installation	Page 29
Needle Bearing Failure	Page 30
Physical Damage	Page 31



On/Off Fan Drive Diagnostic and Service Guide

Additional Support

This guide is intended to assist in troubleshooting the BorgWarner On/Off fan drive, and to identify fan drive failure modes that are warrantable through BorgWarner.

Additional information, including product overview, sales literature, general service, maintenance, disassembly, detailed repair instructions and other service literature is available at:

<http://www.borgwarner.com/en/Thermal/products/Pages/Kysor-On-Off-Fan-Drives.aspx>

For all other questions, Technical Support is available from 8:00am to 5:00pm (Eastern), Monday through Friday, at 1-800-927-7811.

Recommended Practices

For best performance from the BorgWarner On/Off fan drive, follow these recommended practices:

Manually engage the clutch prior to the use of any PTO, and maintain clutch engagement for the duration of PTO usage.

Do not engage the clutch during an engine over-speed condition.

Components of the Fan Drive

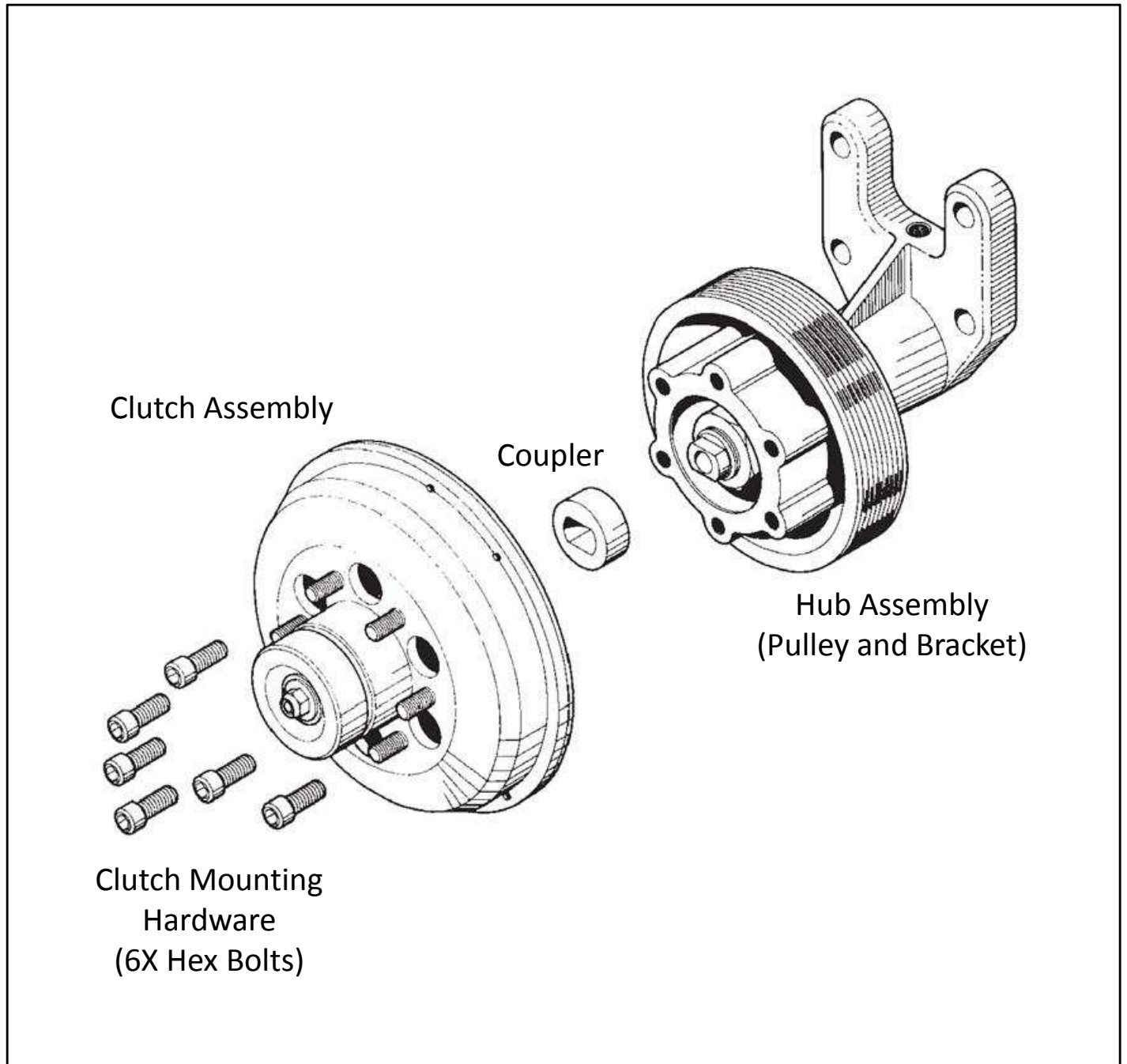

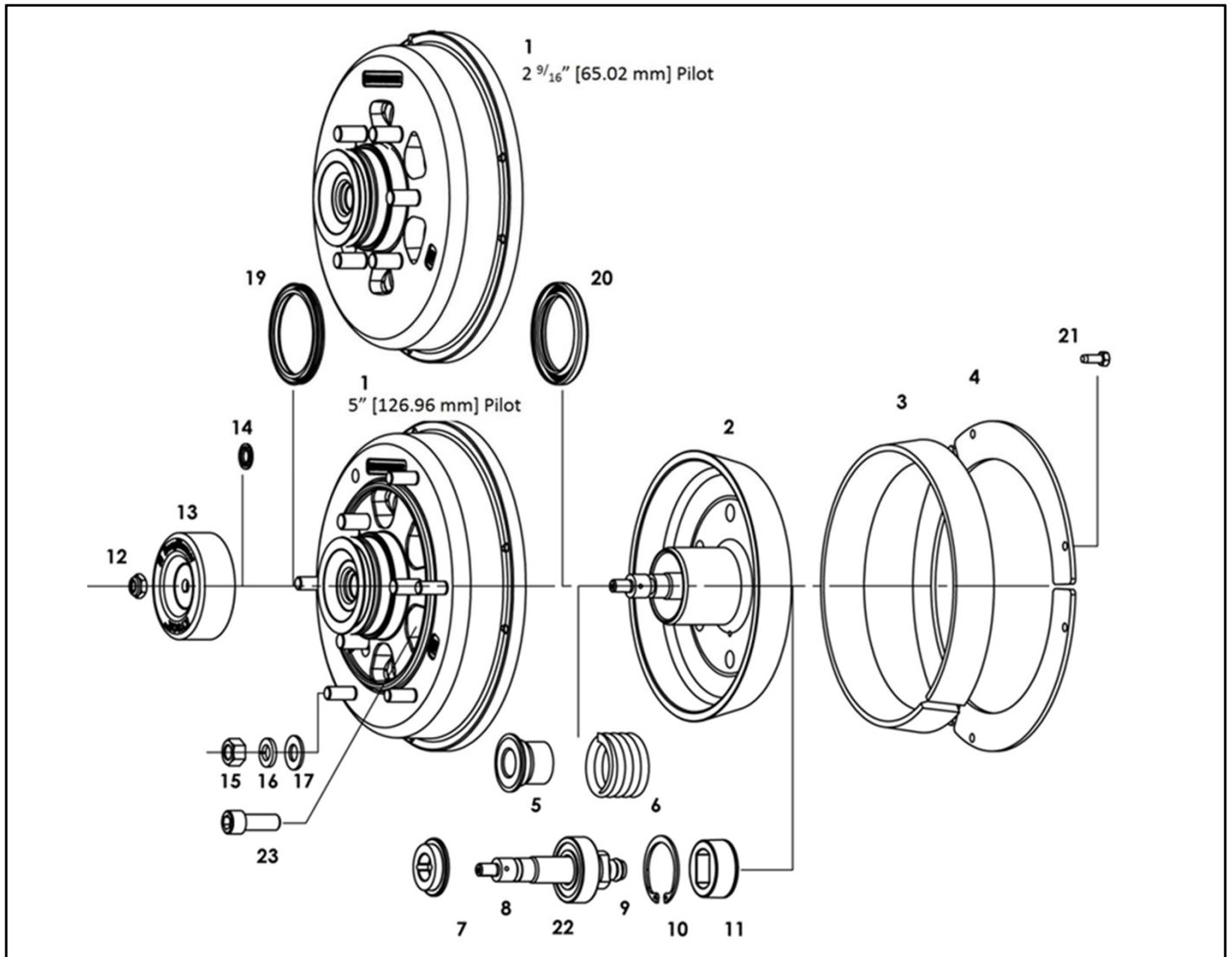
Components of the Clutch Assembly

(1) Clutch Housing; (2) Clutch Shaft; (3) Liner; (4) Retainer Plate; (5) Spring End-Cap; (6) Spring; (7) Spring Carrier; (8) Front O-Ring; (9) O-Ring at Base of Piston Rod; (10) Snap Ring; (11) Coupler; (12) 5/16" Locknut; (13) Cylinder; (14) Seal-Washer; (15) Fan Mounting Nut; (16) Fan Lock-Washer; (17) Fan Flat-Washer; (18) Fan Stud; (19) U-Cup Seal; (20) Grease Seal; (21) Retainer Plate Fastener; (22) Piston Rod and Rear Bearing Assembly; (23) Clutch Mounting Hardware

Housing Cover Aluminum Clutches With 5" Fan Pilot (1090-09900-0xx and 1090-09950-0xx)



Clutch Mount
Access Holes

Hardware



Housing Cover Installed



Housing Cover

These aluminum clutches have a 5-inch diameter fan pilot and use a housing cover to protect the inside of the clutch assembly from foreign debris. The housing cover must be removed to gain access to the clutch mounting hardware. The cover is retained by either 3 serrated flange nuts or a combination of 3 nuts, 3 lock washers and 3 flat washers.

Clutch Repair Kit and Replacement Guide

The following pages provide clutch repair kit and replacement options, including available upgrades.

Caution: Only interchange clutches and components as indicated on the following pages. Failure to follow these guidelines may result in high wear or premature failure.

Kit part numbers for products prior to the K30 series are available in the “BorgWarner Product Catalog”

Repair Kit Contents

Kit Type	Part Description	Quantity
Seal Kit	O-ring at base of piston rod	1
	Cylinder	1
	U-cup seal	1
	Seal-washer	1
	$\frac{5}{16}$ " locknut	1
	Coupler	1
	Grease packet	1
	Front o-ring	1
Liner Kit	Liner	1
	Retainer plate fasteners	6
Seal and Liner Kit	Contents of seal kit	1
	Contents of liner kit	1
	Clutch mounting bolt	6
DuroSpeed™ Liner Kit	Liner	1
	Magnet Ring Fasteners	6
	Coupler	1
	O-ring at base of piston rod	1
	Grease Packet	1
	Clutch Mounting Bolts	6

Clutch Repair Kit and Replacement Guide

Part Number	Product Description
1090-08000-0xx (No Longer Available)	K22 Front Air Clutch
1090-08500-0xx (No Longer Available)	K22 Rear Air Clutch



K22 Rear Air
Pictured

Fan Pilot Diameter = 2 ⁹/₁₆ ”

Repair Kits

Clutch Type	Seals	Liner	Seals and Liner
K22 Front Air	Do not repair, replace with K26 Front Air		
K22 Rear Air	Do not repair, replace with K32 Steel or DuroSpeed™		

Clutch Replacement Options

Clutch Type	Clutch Replacement Options
K22 Front Air	1090-09000-01 – K26 Front Air
K22 Rear Air	1090-09650-01 – K32 1090-29650-01 – DuroSpeed™

Note: the K22 Clutch has a unique liner. This liner cannot be interchanged with any other K-series clutch. The K22 clutch cannot accept a liner from any other K-series clutch.

Clutch Repair Kit and Replacement Guide

Part Number	Product Description
1090-09000-0xx	K26 Front Air Clutch
1090-09500-0xx (No Longer Available)	K26 Rear Air Clutch



Fan Pilot Diameter = 2 ⁹/₁₆''

K26 Rear Air
Pictured

Repair Kits

Clutch Type	Seals	Liner	Seals and Liner
K26 Front Air	4043-41130-01	1033-40600-01	1033-09339-04
K26 Rear Air	1033-08233-01	1033-40600-01	1033-40600-02

Clutch Replacement Options

Clutch Type	Clutch Replacement Options
K26 Front Air	1090-09000-01 – K26 Front Air
K26 Rear Air	1090-09650-01 – K32 1090-29650-01 – DuroSpeed™

Clutch Repair Kit and Replacement Guide

Part Number	Product Description
1090-09600-0xx	K30 Steel Rear Air Clutch



K30 Steel

Fan Pilot Diameter = 2 ⁹/₁₆''

Repair Kits

Clutch Type	Seals	Liner	Seals and Liner
K30 Steel	1033-08233-01	1033-40600-01	1033-40600-02

Note: K30 Steel Clutches can be converted to DuroSpeed™ with the installation of the Retro-fit kit 1033-40700-01.

Clutch Replacement Options

Clutch Type	Clutch Replacement Options
K30 Steel Rear Air Clutch	1090-09650-01 – K32 1090-29650-01 – DuroSpeed™

Clutch Repair Kit and Replacement Guide

**Note: aluminum clutches are offered with 2 fan pilot diameter options*

Part Number	Product Description*
1090-09800-0xx (No Longer Available)	K30 Aluminum Rear Air Clutch 2 9/16" Diameter Fan Pilot
1090-09900-0xx (No Longer Available)	K30 Aluminum Rear Air Clutch 5" Diameter Fan Pilot



K30 Aluminum
With 5" Fan Pilot Pictured

Repair Kits

Current Clutch	Seals	Liner	Seals and Liner
K30 Aluminum (both fan pilot diameters)	Do not repair, replace with K32 Steel or DuroSpeed™		

Clutch Replacement Options

Clutch Type	Clutch Replacement Options
K30 Aluminum Rear Air Clutch 2 9/16" Diameter Fan Pilot	1090-09650-01 – K32 1090-29650-01 – DuroSpeed™
K30 Aluminum Rear Air Clutch 5" Diameter Fan Pilot	1090-09750-01 – K32 1090-29750-01 – DuroSpeed™

Clutch Repair Kit and Replacement Guide

**Note: The K32 steel clutch is offered with 2 fan pilot diameter options*

Part Number	Product Description
1090-09650-0xx	K32 Steel Rear Air Clutch 2 ⁹ / ₁₆ " Diameter Fan Pilot
1090-09750-0xx	K32 Steel Rear Air Clutch 5" Diameter Fan Pilot



K32 Steel
2 ⁹/₁₆" Fan Pilot Pictured

Repair Kits

Clutch Type	Seals	Liner	Seals and Liner
K32 Steel (both fan pilot diameters)	1033-08233-01	1033-40600-01	1033-40600-02

Note: K32 Steel Clutches can be converted to DuroSpeed™ with the installation of the Retro-fit kit 1033-40700-01.

Clutch Replacement Options

Clutch Type	Clutch Replacement Options
K32 Steel Rear Air Clutch 2 ⁹ / ₁₆ " Diameter Fan Pilot	1090-09650-01 – K32 1090-29650-01 – DuroSpeed™
K32 Steel Rear Air Clutch 5" Diameter Fan Pilot	1090-09750-01 – K32 1090-29750-01 – DuroSpeed™

Clutch Repair Kit and Replacement Guide

**Note: aluminum clutches are offered with 2 fan pilot diameter options*

Part Number	Product Description*
1090-09850-0xx (No Longer Available)	K32 Aluminum Rear Air Clutch 2 ⁹ / ₁₆ " Diameter Fan Pilot
1090-09950-0xx (No Longer Available)	K32 Aluminum Rear Air Clutch 5" Diameter Fan Pilot



K32 Aluminum
With 5" Fan Pilot Pictured

Repair Kits

Clutch Type	Seals	Liner	Seals and Liner
K32 Aluminum (both fan pilot diameters)	Do not repair, replace with K32 Steel or DuroSpeed™		

Clutch Replacement Options

Clutch Type	Clutch Replacement Options
K32 Aluminum Rear Air Clutch 2 ⁹ / ₁₆ " Diameter Fan Pilot	1090-09650-01 – K32 1090-29650-01 – DuroSpeed™
K32 Aluminum Rear Air Clutch 5" Diameter Fan Pilot	1090-09750-01 – K32 1090-29750-01 – DuroSpeed™

Clutch Repair Kit and Replacement Guide

Part Number	Product Description*
1090-29650-0xx	DuroSpeed™ Rear Air 2 speed Clutch - 2 9/16" Diameter Fan Pilot
1090-29750-0xx	DuroSpeed™ Rear Air 2 speed Clutch - 5" Diameter Fan Pilot



Note: the DuroSpeed™ clutch may not fit on some pre model year 2007 vehicles. Verify clearance for all rotating parts.

Repair Kits

Clutch Type	Seals	Liner
DuroSpeed™ (Both Fan Pilot Diameters)	1033-08233-01	1033-40700-03

Note: K30 and K32 Steel Clutches can be converted to DuroSpeed™ with the installation of the Retro-fit kit 1033-40700-01 (Do NOT apply to Aluminum or Front Air Clutches).

WARNING!: Always use care in handling this Clutch when the Magnet Ring is exposed. Any interaction with a metallic object may cause a pinch point that could result in personal injury.

WARNING!: Be careful not to handle the clutch by the flux ring. The clutch may fall off unexpectedly causing damage to the clutch or personal injury.

WARNING!: Never operate the clutch without the flux ring in place as damage to the clutch or personal injury could occur. Without the flux ring in place, the magnets on the back of the clutch would be exposed to attract foreign objects and this could create a hazard.

Note – A conversion kit is required to convert to On/Off fan clutch operation. For further information on conversion kits, contact Technical Service at 800-927-7811.

Removal of the Clutch Assembly

Troubleshooting the fan drive should begin with the clutch assembly still installed on the vehicle. However, at some point during the troubleshooting process, it may become necessary to remove the clutch assembly. Below is a procedure for removing the clutch assembly from the hub assembly:

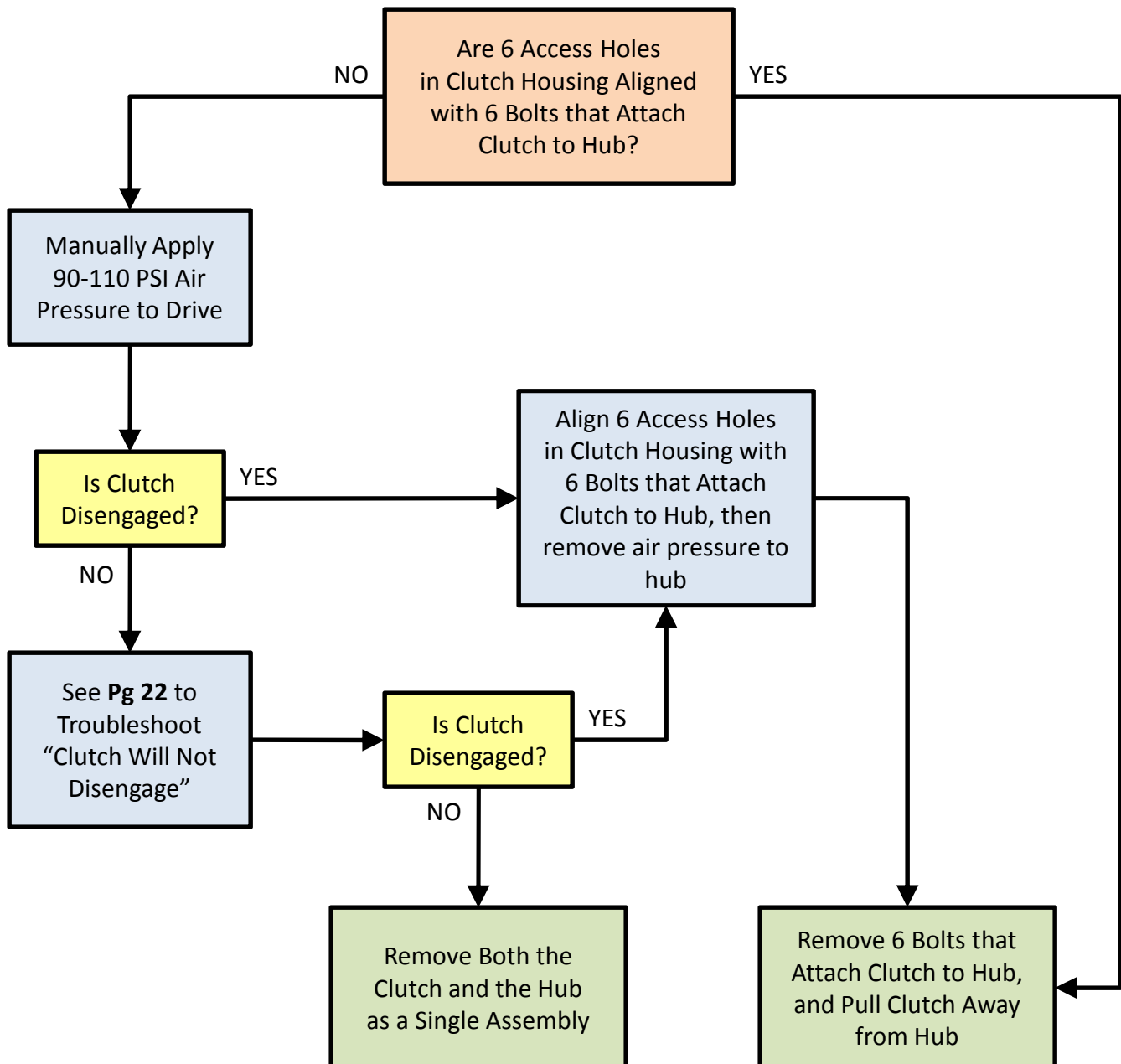

Inspecting the Pulley (Hub) Assembly for Play

The hub assembly may be inspected for play, with or without the clutch installed. For best results, use the following procedure:

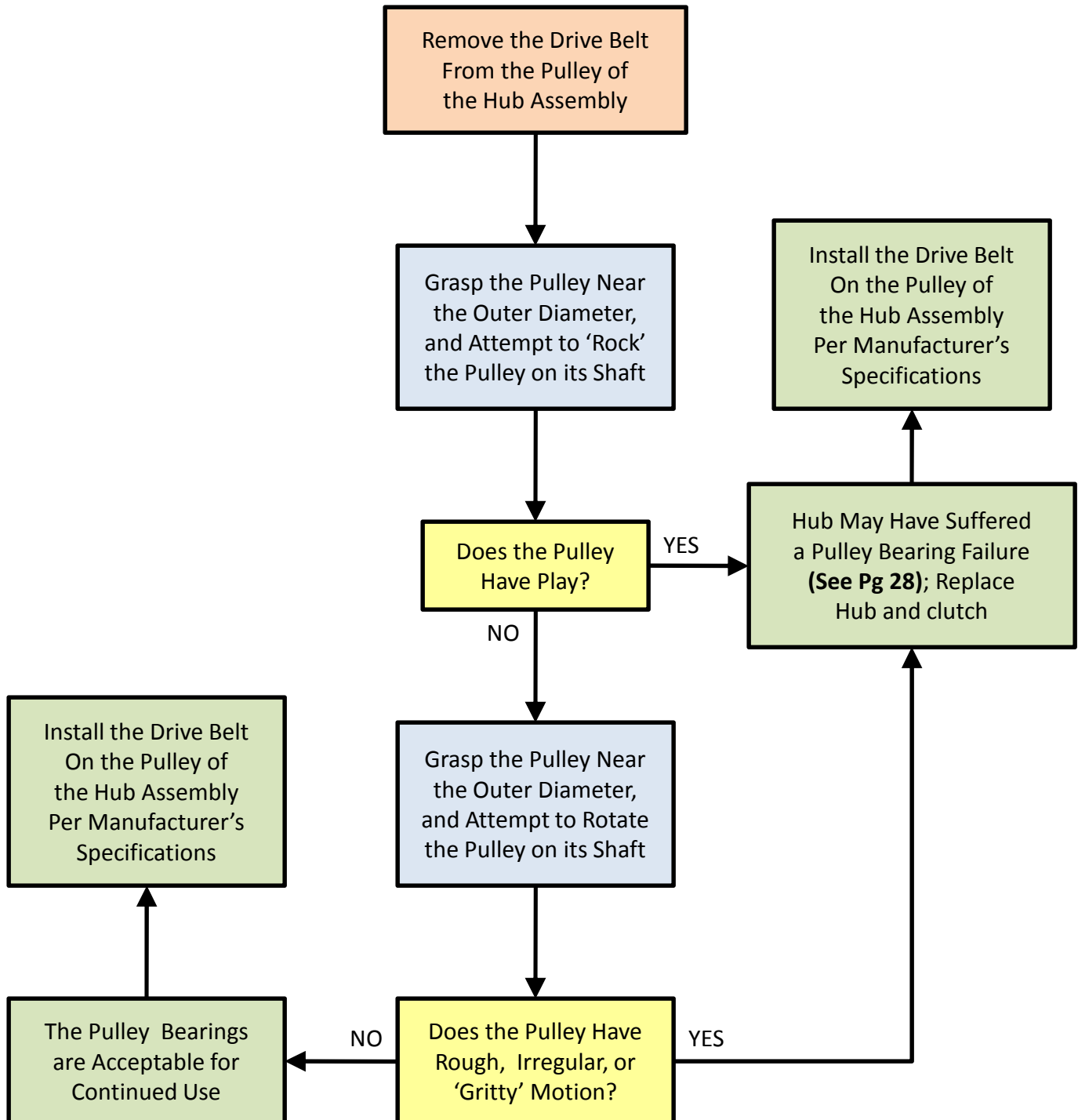

Inspecting the Clutch Assembly for Play

Supply 90-110 PSI air pressure to the fan drive to disengage the clutch. Setup a dial indicator on a flat rear surface of the fan, very close to the outer rim of the clutch (see the image to the upper left).

Grasp the fan as close to the position of the dial indicator as possible (see the image to the upper right). Gently move the fan forward and rearward (do not force), and record the total indicator reading.

If the total indicator reading exceeds 0.050" (1.27mm) then the clutch should be replaced. If the total indicator reading is less than or equal to 0.050" (1.27mm) then the amount of clutch play is acceptable.

Checking the Remaining Liner Life On/Off



Liner Life Remaining



Liner Replacement Necessary

Remaining liner life may be checked by using the Service Alert Tool. This tool is available for no cost at www.borgwarner.com/thermallit.

Start with the clutch engaged (no air pressure to the drive). Place the Service Alert Tool flush against the rear face of the clutch shaft as shown in the images above (this may be done with the clutch installed on the vehicle).

If the Service Alert Tool sits below the surface of the retainer plate (as shown in the image on the left) then the liner has life remaining. If the Service Alert Tool sits above the surface of the retainer plate (as shown in the image on the right) then the liner should be replaced as soon as possible. See Pg 26 to determine whether a control system issue is responsible for rapid liner wear.

Note: the Service Alert Tool has a thickness of 0.062" – if the Service Alert Tool is not available, then the liner should be replaced when the clutch shaft's rear face is less than 0.062" forward of the retainer plate's rear face.

Checking the Remaining Liner Life DuroSpeed™



Liner Life Remaining



Liner Replacement Necessary

Remaining liner life may be checked by using a United States Dime.

Start with the clutch engaged (no air pressure to the drive). Place the United States Dime against the cooling fins of the flux ring as shown in the pictures above.

If the United States Dime slides **AGAINST** the outer edge of the lining retaining ring then the liner has remaining life. If the United States Dime slides **UNDERNEATH** the lining retaining ring then the lining should be replaced as soon as possible. See Pg 26 to determine whether a control system issue is responsible for rapid liner wear.

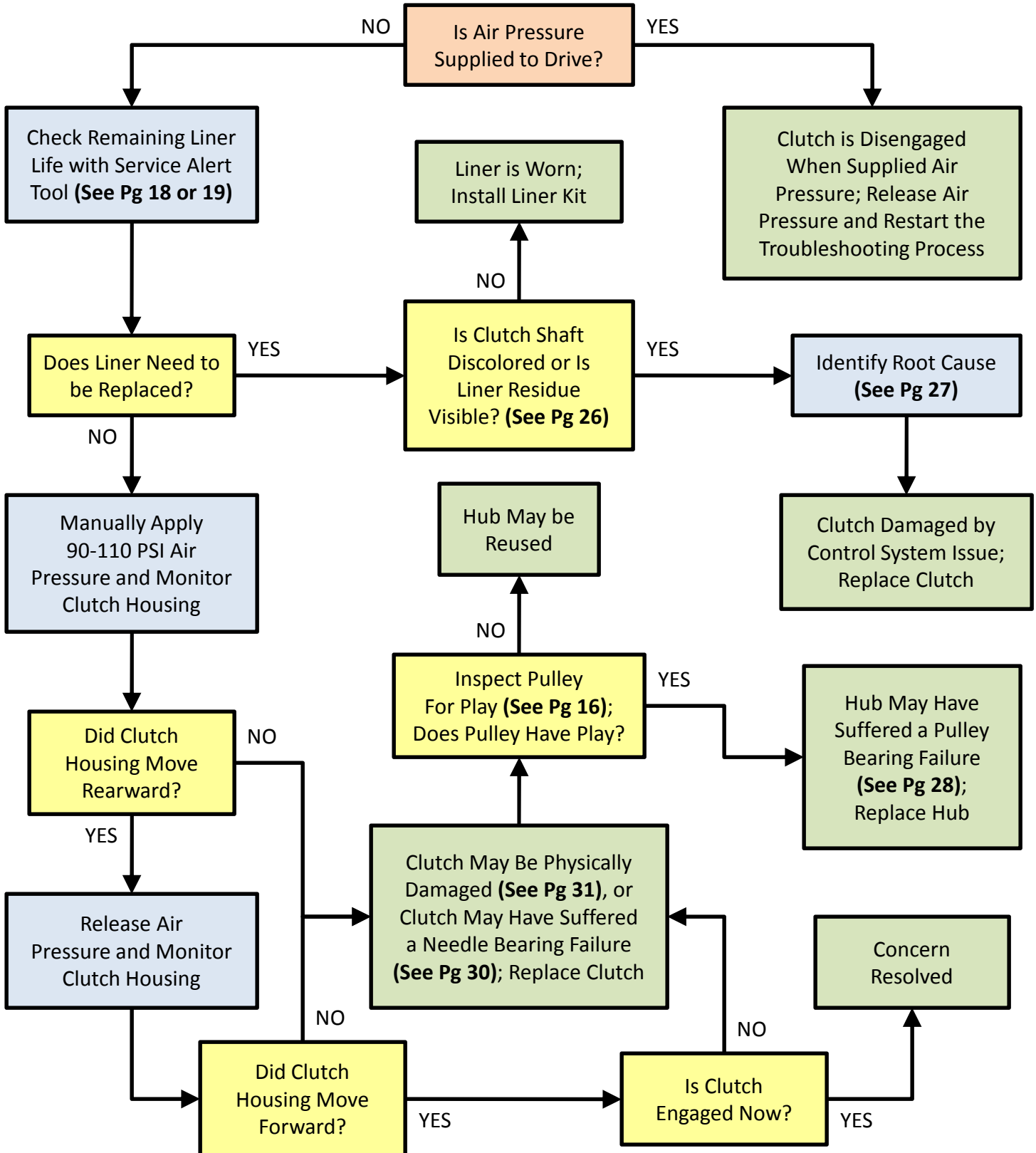
Troubleshoot: Clutch Will Not Engage

On/Off Fan Drive Diagnostic and Service Guide

Troubleshoot: Fan Drive Has An Air Leak

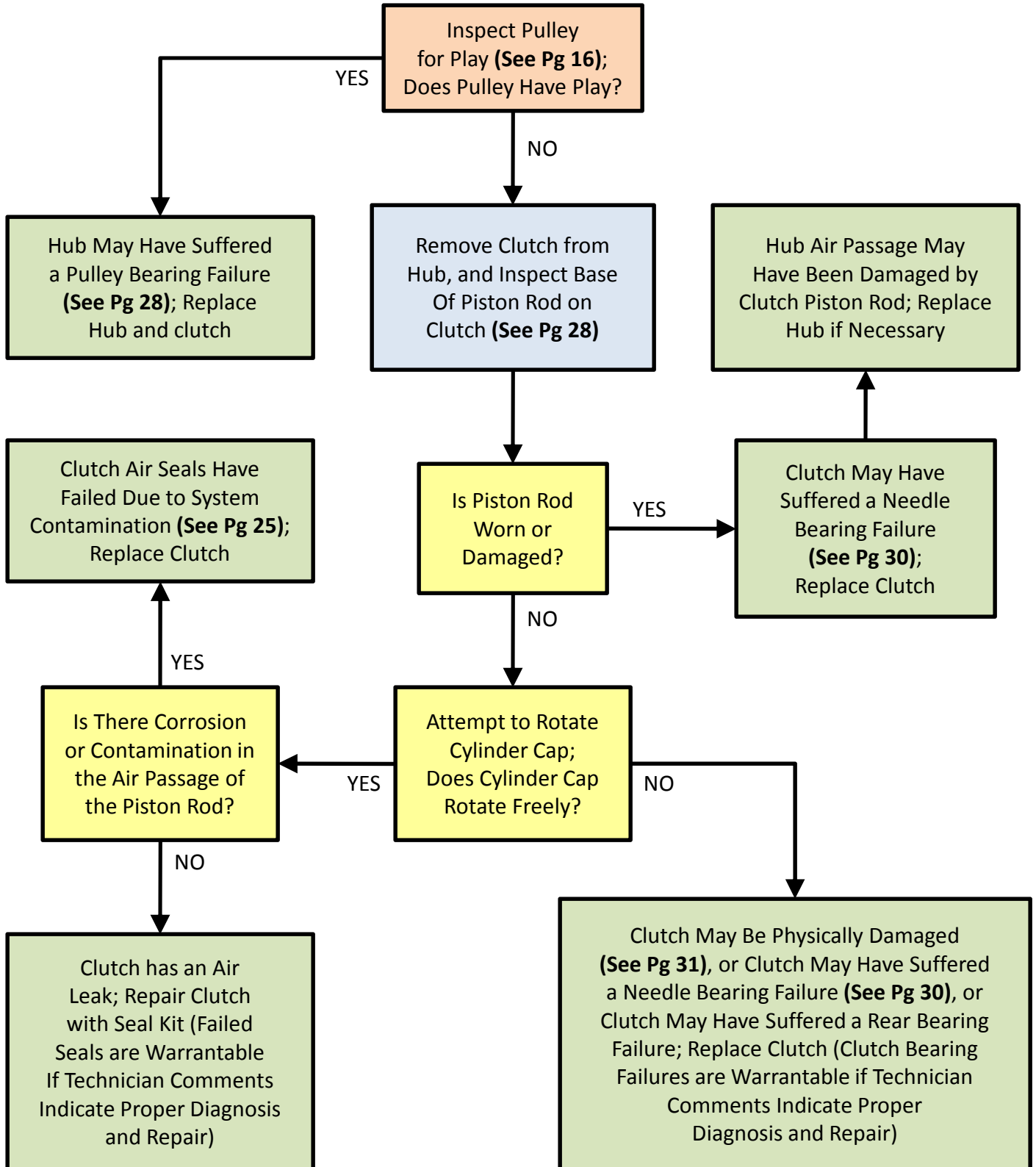

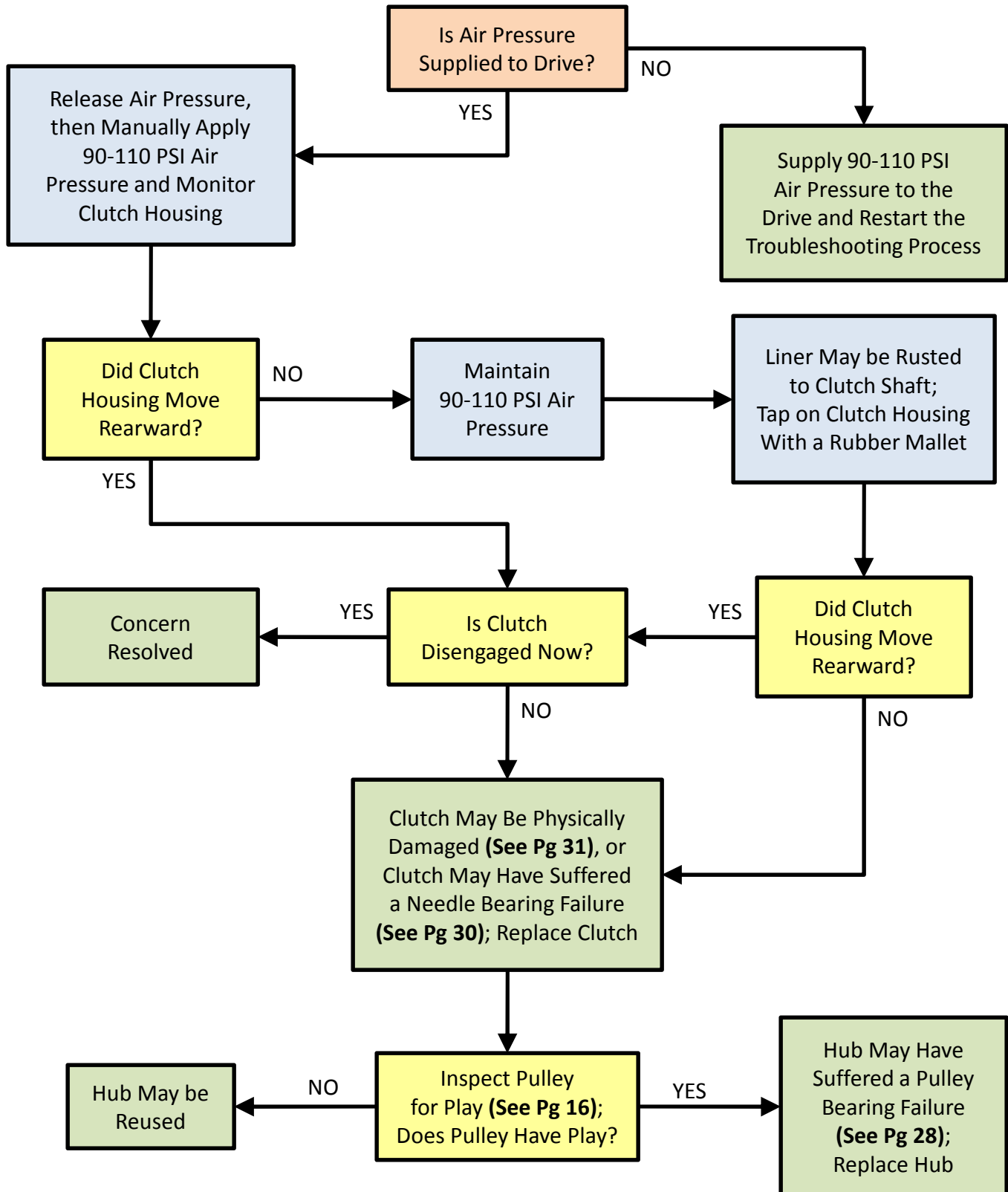
Troubleshoot: Clutch Will Not Disengage (If Air Leak, See Pg 21)

Troubleshoot: Fan Drive Has Play

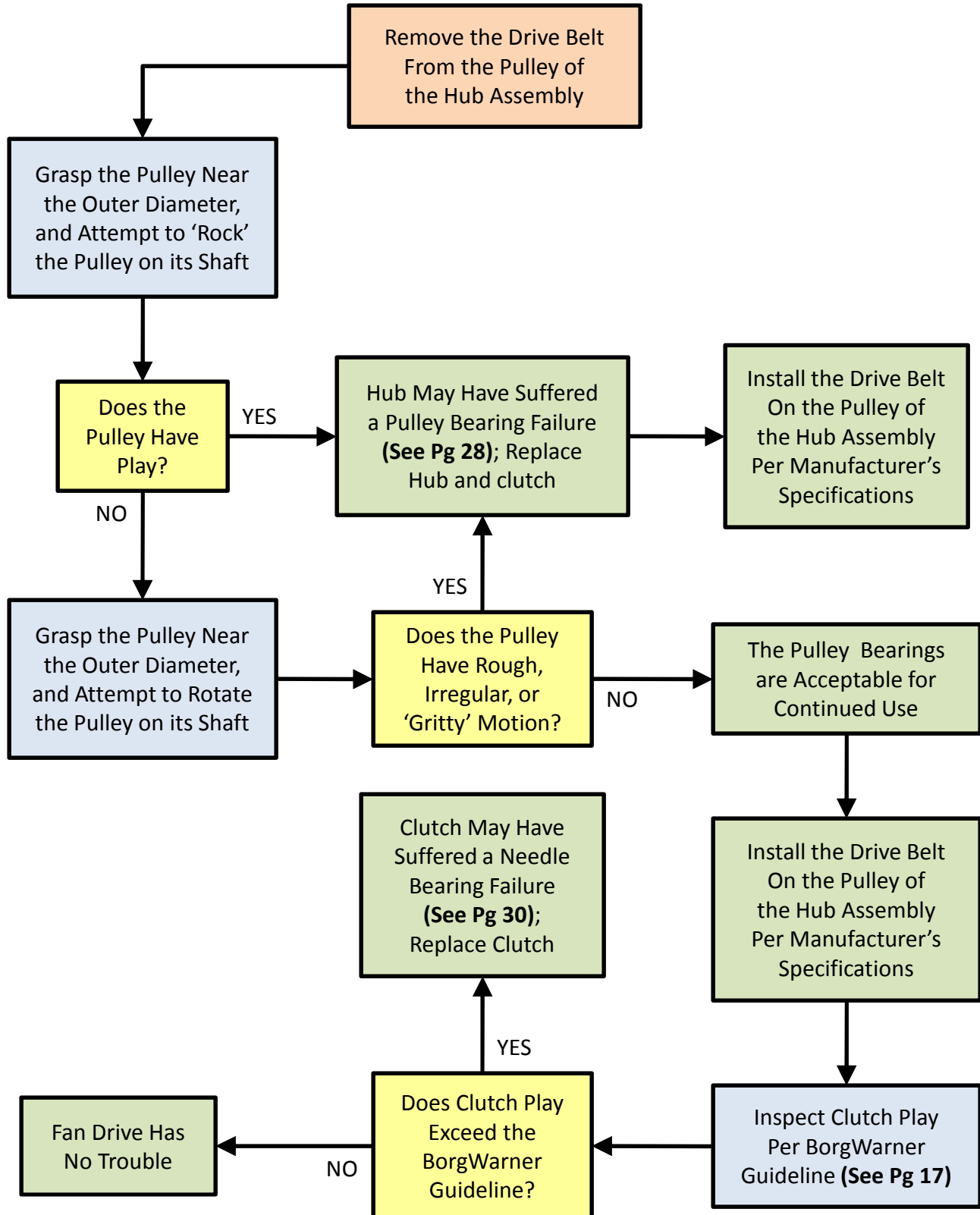

Clutch Failure Modes and Warranty Coverage

Note: The troubleshooting guides should be used to determine the root cause of a clutch failure before referring to this section (see “Troubleshoot” in the Index on Pg 2).

The following pages illustrate the possible failure modes of the clutch assembly. **Disassembly of the clutch is not necessary to diagnose the failure mode.**

Failure Mode:

Air System Contamination	Page 25
Control System Issue	Page 26
Control System Issue (Root Causes)	Page 27
Evidence of Pulley Bearing Failure	Page 28
Improper Installation	Page 29
Needle Bearing Failure	Page 30
Physical Damage	Page 31

Air System Contamination

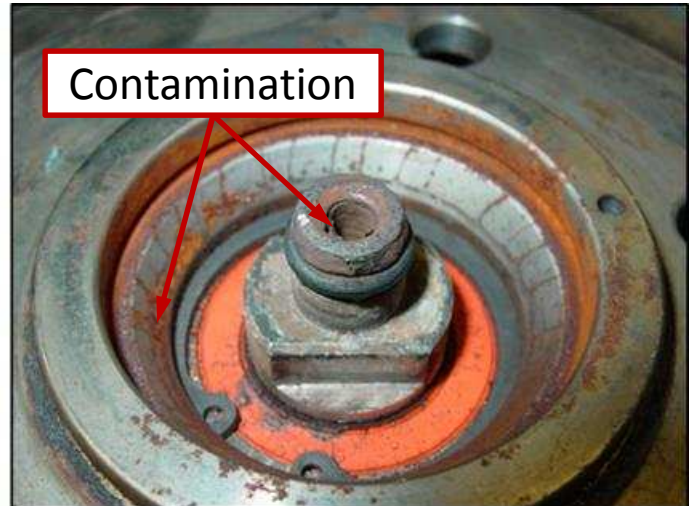
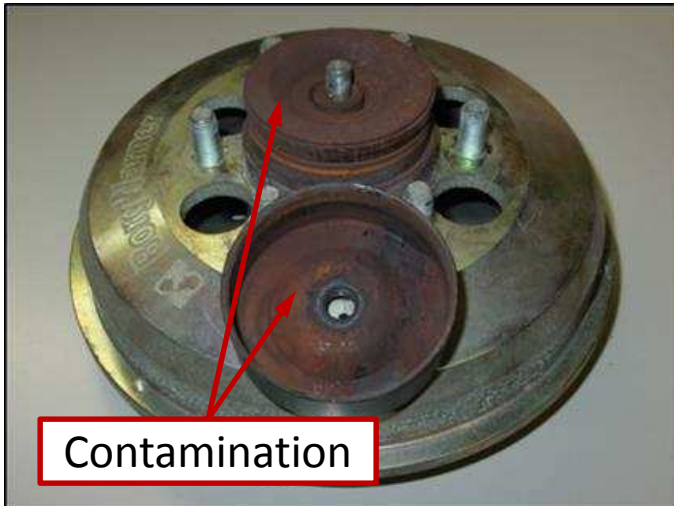

Disassembly of the clutch is not required - images are provided for reference only. Contamination in the air system may cause air seal leaks, operation troubles, or clutch failure. **Any failure due to air system contamination is not warrantable through BorgWarner.**

Control System Issue

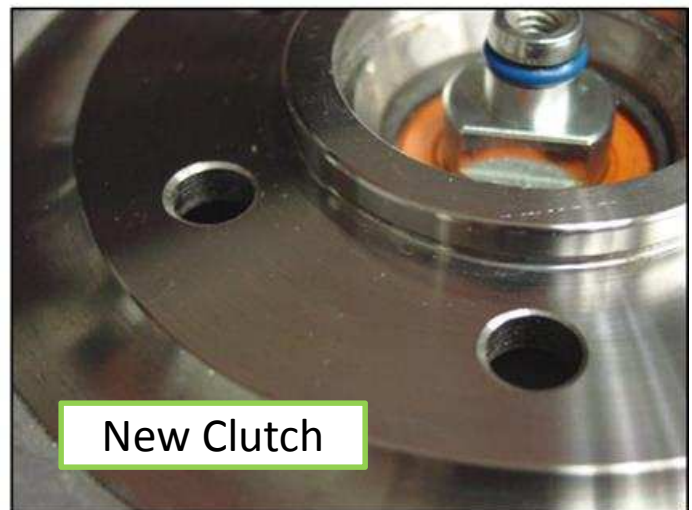
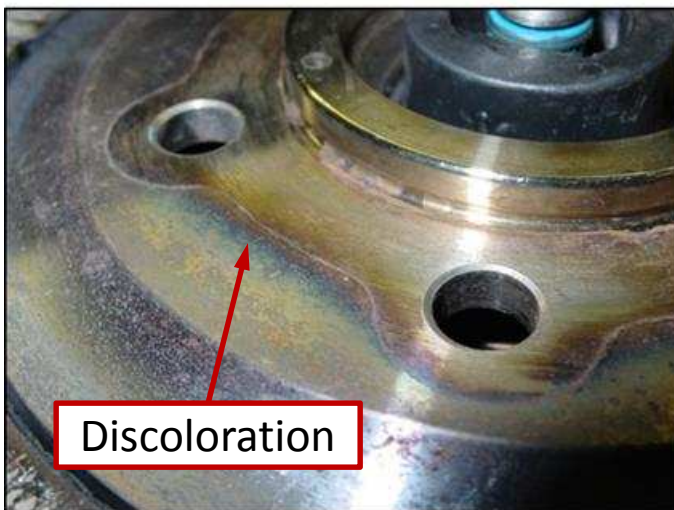
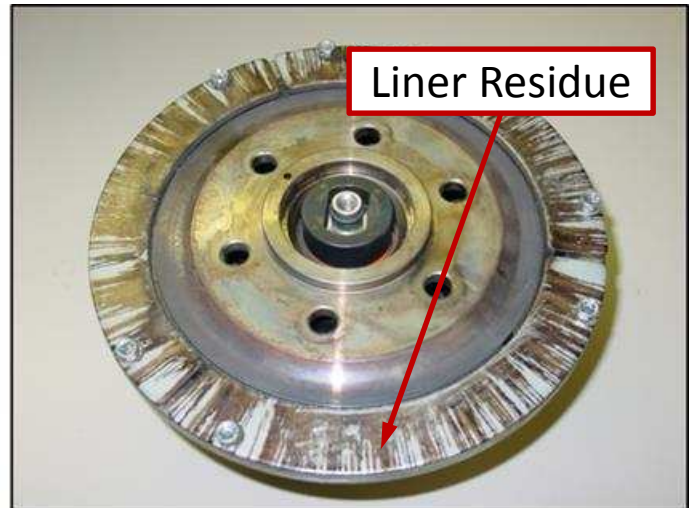
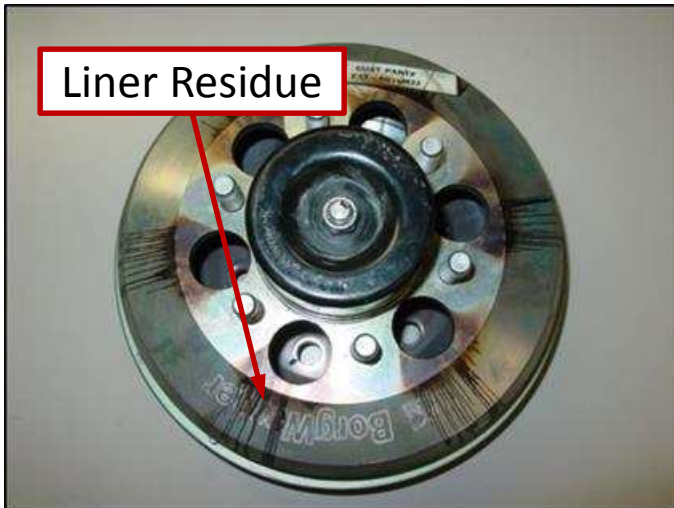

A control system issue (potential root causes identified on Pg 27) or restricted fan rotation may cause the clutch to overheat and ultimately fail. Evidence of an overheated clutch includes liner residue on the forward and/or rear face of the clutch, discoloration of the rear face of the clutch, an extremely worn liner, or even a melted coupler. **Any failure due to a control system issue is not warrantable through BorgWarner – check with the OEM for possible warranty coverage.**

Control System Issue (Root Causes)

Control system issues, which may cause the clutch to wear excessively or overheat, include any of the following root causes:

- Incomplete clutch disengagement (liner still in contact) due to air pressure below 90 PSI. Verify that air pressure at the hub fitting is 90-110 PSI when the clutch is disengaged.
- Slow clutch disengagement due to a low air flow rate caused by a contaminated air solenoid, pinched air line, air leak, or high air demand. Verify that air pressure at the hub fitting increases almost instantaneously from 0 PSI to at least 90 PSI (in less than 1 second).
- Slow clutch disengagement or incomplete clutch disengagement due to insufficient air pressure or insufficient air flow rate ultimately caused by vehicle electrical issues. Verify that air pressure at the hub fitting increases almost instantaneously from 0 PSI to at least 90 PSI (in less than 1 second).
- Slow clutch engagement due to a plugged air vent, a contaminated air solenoid, or a pinched air line (air pressure must be released quickly to engage clutch with minimal slippage). Verify that air pressure at the hub fitting decreases almost instantaneously from more than 90 PSI down to 0 PSI (in less than 1 second).
- Frequent clutch (and fan) engagements lasting less than 30 seconds (clutch over-cycling) due to the lack of a fan “on-time” timer within the engine or vehicle control module, A/C problems, or defective control system.

Indications of Pulley Bearing (Hub) Problems



Damage to the base of the piston rod or o-ring; a rounded out or melted coupler may be caused by pulley bearing problems. Inspect for play or rough motion in the pulley bearings (See Pg 16). **If a clutch is damaged by pulley bearing problems, and the hub is still under warranty, then both the clutch and hub must be returned to BorgWarner for warranty consideration.**

Improper Installation



Any extra bolts left loose inside the clutch housing will cause internal damage during clutch operation. Any of the 6 clutch mounting bolts that are not torqued to 45 lbf-ft (61 Nm) may become loose inside the clutch housing and cause internal damage. Bolts that are properly torqued will leave a witness mark in the clutch shaft. **A failure due to improper installation is not warrantable through BorgWarner, unless the failure occurred on an original equipment factory installation.**

Needle Bearing Failure



Disassembly of the clutch is not required - images are provided for reference only. Needle bearing problems are rare, but can occur. **If a needle bearing fails due to a hub failure (see Pg 28), and the hub is still under warranty, then both the clutch and hub must be returned for warranty consideration.** If a needle bearing fails without a hub failure, then the clutch alone may be returned for warranty consideration. A needle bearing failure due to a defect in material or workmanship is warrantable through BorgWarner.

Physical Damage



Crooked Cylinder Cap



Impact



Broken Housing

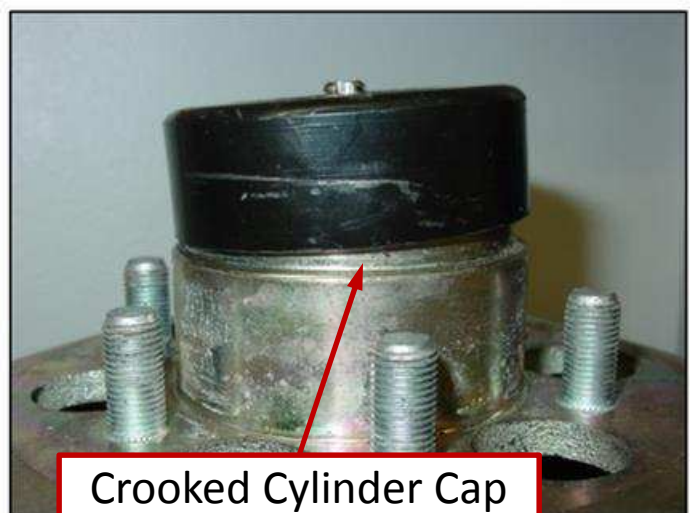

Crooked Cylinder Cap

An impact to the cylinder cap may bend the piston rod (which carries the cylinder cap) and produce an air seal leak. The bent piston rod may even prevent the clutch from engaging or disengaging. An impact to the clutch housing, especially near a fastener hole, may fracture the housing and cause a fastener to become loose or lost. **A failure due to physical damage of any kind is not warrantable through BorgWarner.**