

S500SX

900 - 1475 HP Turbo



S500SX

900 - 1575 HP Turbo



- Twin hydrodynamic journal bearings
- Extended Tip Technology Compressor Wheel
- Available in twin scroll and open flow turbine volute options
- Adjustable compressor and turbine housing orientation

- Compressor cover recirculation grooves
- Optimized compressor inlet geometry
- Dual machined compressor cover discharge connection (v-band or hose bead)
- Premachined speed sensor mounting boss



Turbo Part #	Comp. Wheel O.D. (in)	Comp. Wheel O.D. (mm)	Comp Wheel Inducer Dia. (in)	Comp Wheel Inducer Dia. (mm)	Turbine Wheel O.D. (in)	Turbine Wheel O.D. (mm)	Turbine Wheel Exducer (in)	Turbine Wheel Exducer (mm)	Turbine Housing A/R	Super-Core	Cartridge Assembly	Service Kit (360° thrust bearing)
179188	4.73	120.20	3.47	88.19	4.32	109.73	3.90	99.08	0.85	179186*	179187	173611
179191	4.73	120.20	3.57	90.67	4.32	109.73	3.90	99.08	0.85	179190*	179189	173611

* Super-Core options found on page 56

See page 61 for speed sensor installation details

COMPRESSOR MAPS

S500SX 900 - 1475 HP Turbo Part #: 179188

Comp. Wheel Inducer Dia. (mm) 88.19
Comp. Wheel Outer Dia. (mm) 120.20

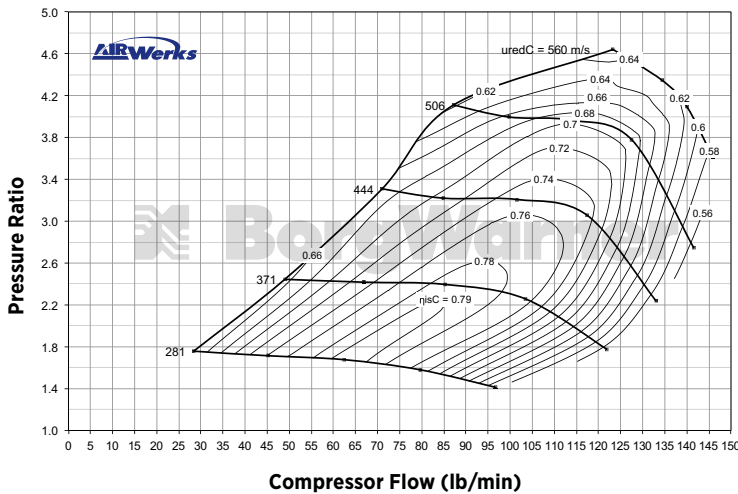

S500SX 900 - 1575 HP Turbo Part #: 179191

Comp. Wheel Inducer Dia. (mm) 90.67
Comp. Wheel Outer Dia. (mm) 120.20

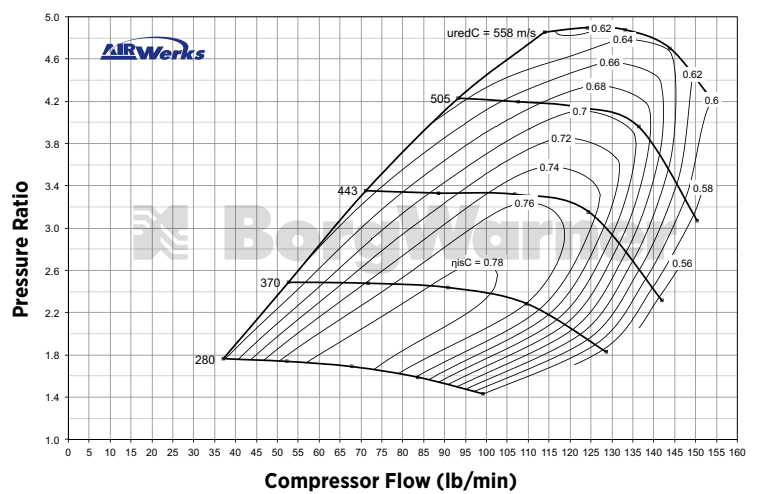

S500SX

TURBO FRAME DIMENSIONS

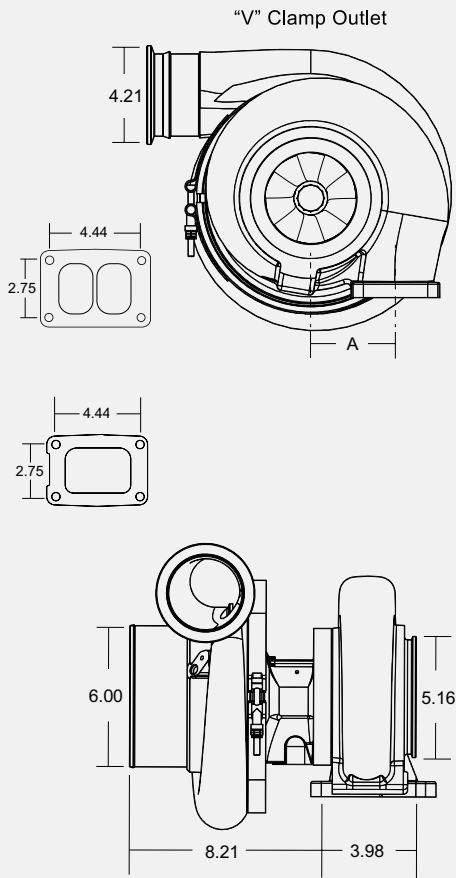

S500SX Super-Core

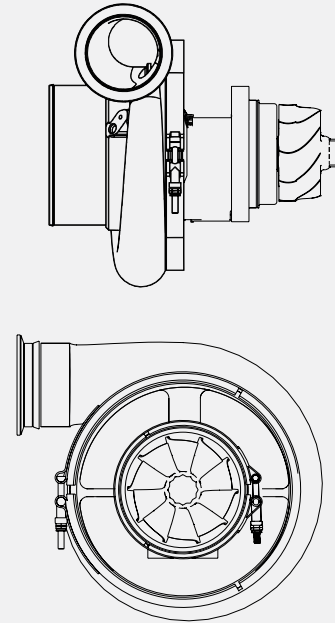

T6

TURBO FRAME DIMENSIONS

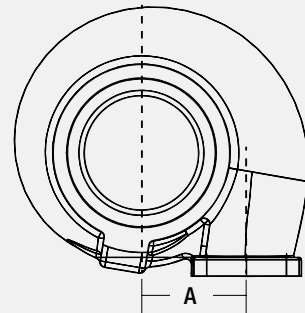
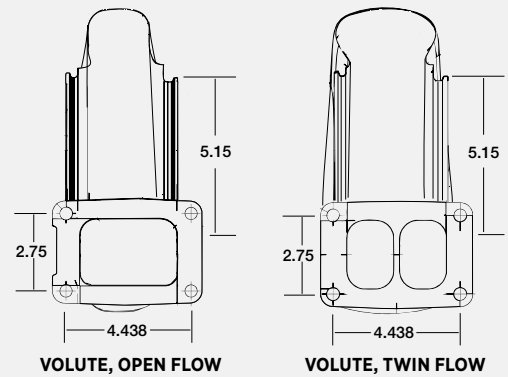

TURBINE HOUSING

Part #	A/R	Turbine Inlet Centerline (A)	Other Notes
179159	0.85	3.62"	Volute, Open Flow
179160	1.00	3.62"	Volute, Open Flow
179161	1.15	4.25"	Volute, Open Flow
178498	1.30	3.62"	Volute, Open Flow; .50" Longer Turbine Discharge
179162	1.45	4.25"	Volute, Open Flow
179478	1.15	3.62"	Volute, Twin Flow (Divided)
179192	1.45	3.62"	Volute, Twin Flow (Divided)
179193	1.60	3.62"	Volute, Twin Flow (Divided)

110MM (O.D.) TURBINE WHEEL

Component	Part #	Part #
Turbo	179188	179191
Super-Core	179186	179190