

# S500SX-E

900 - 1875 HP Turbo

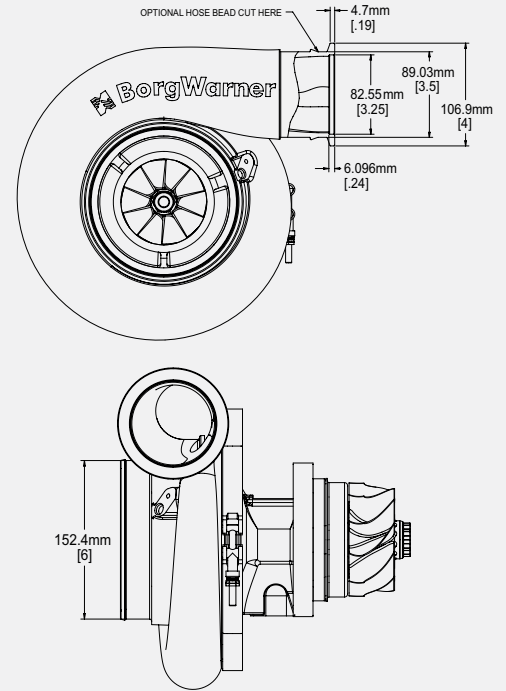

## TURBO FRAME DIMENSIONS



## FEATURES

- Twin hydrodynamic journal bearings
- Extended Tip Technology Compressor Wheel
- Twin Scroll Turbine Housing
- Adjustable compressor and turbine housing orientation
- Standard turbine inlet and outlet connections
- Compressor cover recirculation grooves



Super- Core	Comp. Wheel O.D. (in)	Comp Wheel O.D. (mm)	Comp Wheel Inducer Dia. (in)	Comp Wheel Inducer Dia. (mm)	Turbine Wheel O.D. (in)	Turbine Wheel O.D. (mm)	Turbine Wheel Ex-ducer	Turbine Wheel Exducer (mm)	Service Kit (360° thrust bearing)
15009097001	4.72	120.00	3.46	87.93	4.32	109.73	3.90	99.08	173611
15009097002	4.72	120.00	3.69	93.80	4.32	109.73	3.90	99.08	173611

## TURBINE HOUSING

\*See page 56

See page 61 for speed sensor installation details

Part #	A/R	Inlet Configuration	Turbine Inlet to Centerline*	Notes
179159	0.85	Volute, Open Flow	3.62"	110 Turbine Wheel
179160	1.00	Volute, Open Flow	3.62"	
179161	1.15	Volute, Open Flow	4.25"	
178498	1.30	Volute, Open Flow (50" longer discharge)	3.62"	
179162	1.45	Volute, Twin Flow	4.25"	
179478	1.15	Volute, Twin Flow	3.62"	
179192	1.45	Volute, Twin Flow	3.62"	
179193	1.60	Volute, Twin Flow	3.62"	

## COMPRESSOR MAPS

### S500SX-E 900 - 1650 HP Part #: 15009097001

Comp. Wheel Inducer Dia. (mm) 87.93  
Comp. Wheel Outer Dia. (mm) 120.00

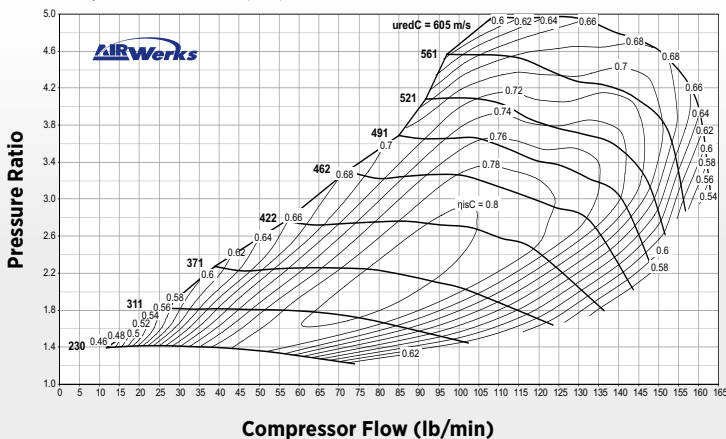

### S500SX-E 900 - 1875 HP Part #: 15009097002

Comp. Wheel Inducer Dia. (mm) 93.80  
Comp. Wheel Outer Dia. (mm) 120.00

