

S400SX4

500 - 1050 HP Turbo



FEATURES

- Twin hydrodynamic journal bearings
- Extended tip technology compressor wheel
- Twin scroll turbine housing
- Adjustable compressor and turbine housing orientation
- Compressor cover recirculation grooves



TURBO FRAME DIMENSIONS

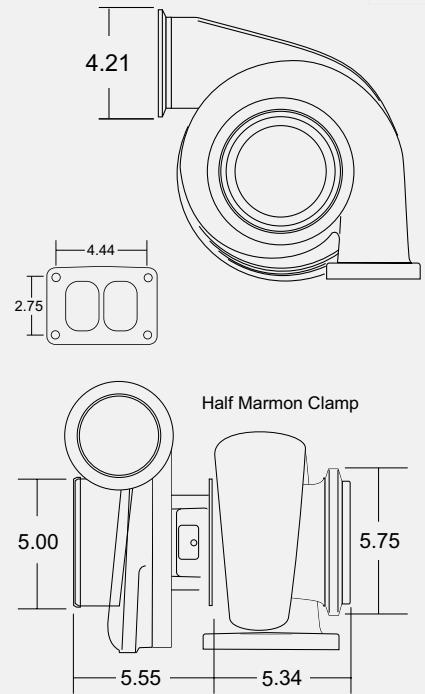

Turbo Part #	Comp. Wheel O.D. (in)	Comp Wheel O.D. (mm)	Comp Wheel Inducer Dia. (in)	Comp Wheel Inducer Dia. (mm)	Turbine Wheel O.D. (in)	Turbine Wheel O.D. (mm)	Turbine Wheel Exducer (in)	Turbine Wheel Exducer (mm)	Turbine Housing A/R	Cartridge Assembly	Service Kit (Standard)	Service Kit (360° thrust bearing)
171701	3.94	100.17	2.80	71.08	3.77	95.70	3.47	88.05	1.32	171699	176391	14007110003
171702	3.94	100.17	2.94	74.56	3.77	95.70	3.47	88.05	1.32	171703	176391	14007110003
176806	3.94	100.17	2.94	74.56	3.29	83.47	3.29	74.29	1.10	176807	318396	14007110000

COMPRESSOR MAP / APPLICABLE TO PART NUMBER 171702 AND 176806

Comp. Wheel Inducer Dia. (mm) 74.56
Comp. Wheel Outer Dia. (mm) 100.17

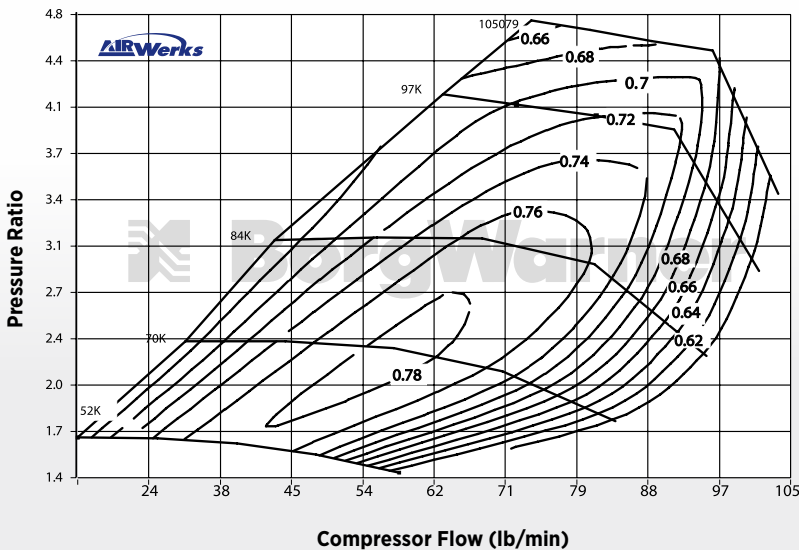

TURBINE HOUSING FOR 176806 ONLY

Part #	A/R	Inlet Configuration	Notes
176809	0.90	Volute, Twin Flow T6 Inlet	83mm Turbine Wheel
176810	1.00		
176811	1.10		
176812	1.25		

TURBINE HOUSING FOR 171701 AND 171702

Part #	A/R	Inlet Configuration	Notes
14961019007	1.15	Volute, Twin Flow T6 Inlet	96mm Turbine Wheel
171698	1.32		
14961016101	1.45		
14961016100	1.58		

S400SX4

750 - 1250 HP Turbo



FEATURES

- Twin hydrodynamic journal bearings
- Extended tip technology compressor wheel
- Twin scroll turbine housing
- Adjustable compressor and turbine housing orientation
- Compressor cover recirculation grooves



TURBO FRAME DIMENSIONS

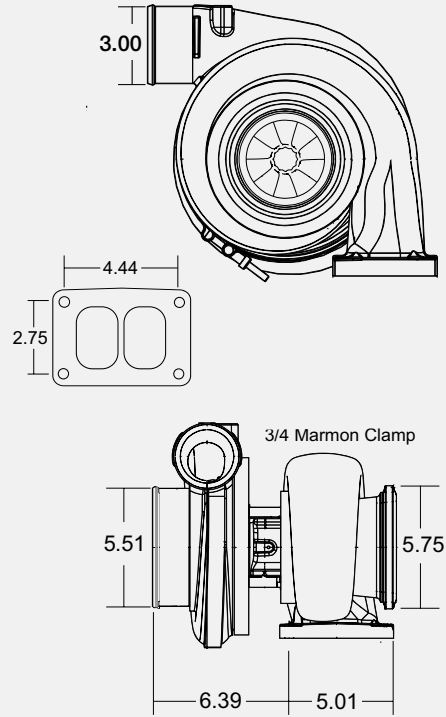

Turbo Part #	Comp. Wheel O.D. (in)	Comp Wheel O.D. (mm)	Comp Wheel Inducer Dia. (in)	Comp Wheel Inducer Dia. (mm)	Turbine Wheel O.D. (in)	Turbine Wheel O.D. (mm)	Turbine Wheel Exducer (in)	Turbine Wheel Exducer (mm)	Turbine Housing A/R	Cartridge Assembly	Service Kit (Standard)	Service Kit (360° thrust bearing)
177287	4.32	109.73	3.16	80.30	3.77	95.70	3.47	88.05	1.32	176654	176391	14007110003

COMPRESSOR MAP

Comp. Wheel Inducer Dia. (mm) 80.30
Comp. Wheel Outer Dia. (mm) 109.73

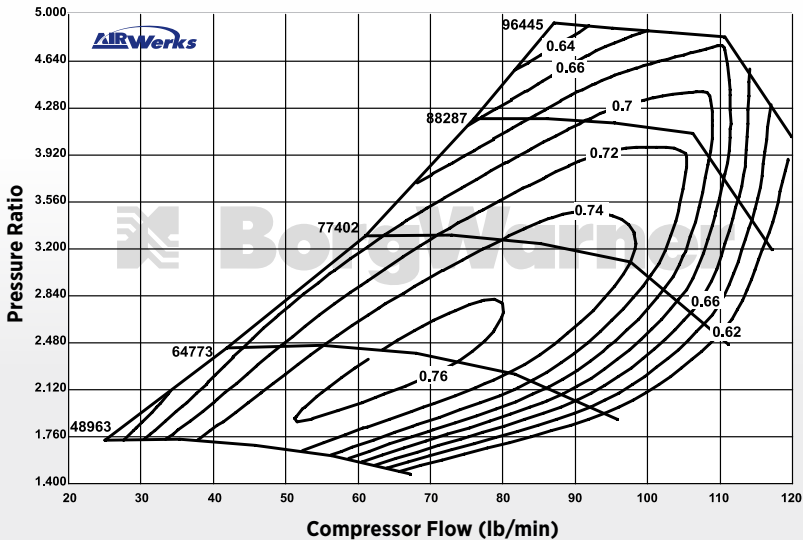

TURBINE HOUSING

Part #	A/R	Inlet Configuration	Notes
14961019007	1.15	Volute, Twin Flow T6 Inlet	96mm Turbine Wheel
171698	1.32		
14961016101	1.45		
14961016100	1.58		