

S400SX-E

500 - 1200 HP Turbo



FEATURES

- Twin hydrodynamic journal bearings
- Extended Tip Technology Compressor Wheel
- Twin Scroll Turbine Housing
- Adjustable compressor and turbine housing orientation
- Standard turbine inlet and outlet connections
- Compressor cover recirculation grooves



SUPER-CORE FRAME DIMENSIONS

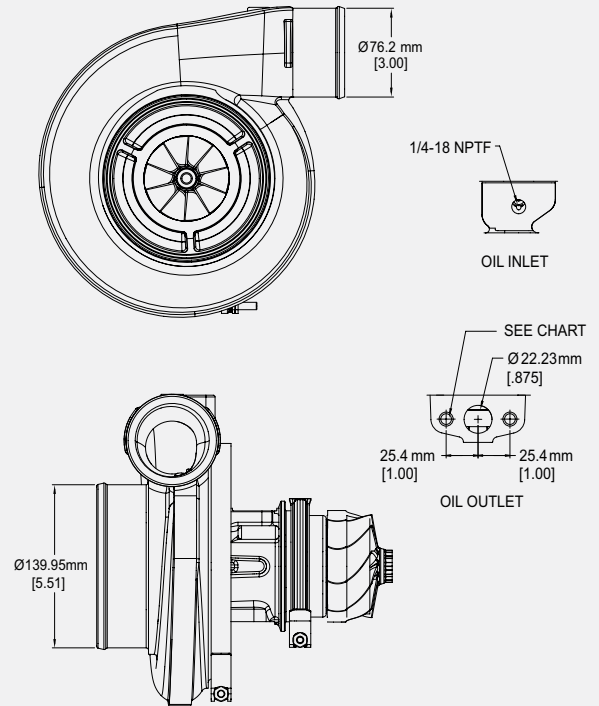

Super-Core	Comp. Wheel O.D. (in)	Comp Wheel O.D. (mm)	Comp Wheel Inducer Dia. (in)	Comp Wheel Inducer Dia. (mm)	Turbine Wheel O.D. (in)	Turbine Wheel O.D. (mm)	Turbine Wheel Exducer (in)	Turbine Wheel Exducer (mm)	Oil outlet thread	Service Kit (360° thrust bearing)
14009097006	3.78	96.00	2.83	72.00	3.44	87.37	3.22	81.74	M8 X 1.25	14007110000
14009097014	3.94	100.00	2.99	76.00	3.44	87.37	3.22	81.74	M10 X 1.5	14007110000

TURBINE HOUSING

Part #	A/R	Inlet Configuration	Notes
178787	0.90	Volute, Twin Flow	87mm Turbine Wheel
178788	1.00		
178789	1.10		
178790	1.25		

COMPRESSOR MAPS

S400SX-E 500 - 1100 HP Part #'s: 14009097006

Comp. Wheel Inducer Dia. (mm) 72.00
Comp. Wheel Outer Dia. (mm) 96.00

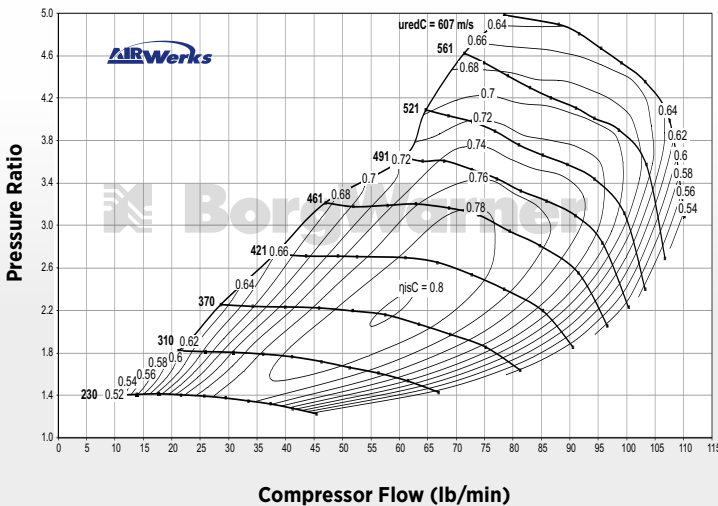

S400SX-E 550 - 1200 HP Part #'s: 14009097013 & 14009097014

Comp. Wheel Inducer Dia. (mm) 76.00
Comp. Wheel Outer Dia. (mm) 100.00

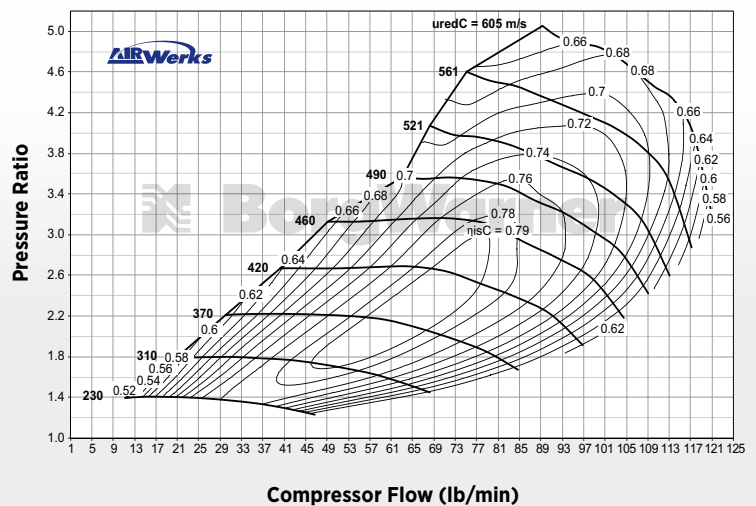

S400SX-E

650 - 1575 HP Turbo



FEATURES

- Twin hydrodynamic journal bearings
- Extended Tip Technology Compressor Wheel
- Twin Scroll Turbine Housing
- Adjustable compressor and turbine housing orientation
- Standard turbine inlet and outlet connections
- Compressor cover recirculation grooves

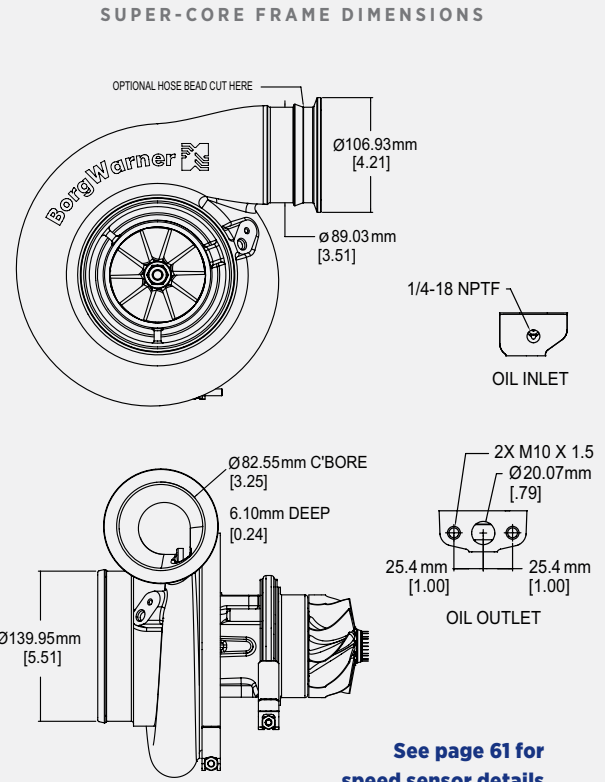

Super-Core	Comp. Wheel O.D. (in)	Comp Wheel O.D. (mm)	Comp Wheel Inducer Dia. (in)	Comp Wheel Inducer Dia. (mm)	Turbine Wheel O.D. (in)	Turbine Wheel O.D. (mm)	Turbine Wheel Exducer (in)	Turbine Wheel Exducer (mm)	Service Kit (360° thrust bearing)
*14009097013	3.94	100.00	2.99	76.00	3.77	95.70	3.47	88.05	14007110003
14009097010	4.33	110.00	3.16	80.30	3.77	95.70	3.47	88.05	14007110003
14009097008	4.33	110.00	3.46	87.93	3.77	95.70	3.47	88.05	14007110003

*See page 46 for compressor map

TURBINE HOUSING

Part #	A/R	Inlet Configuration	Notes
14961019007	1.15	Volute, Twin Flow	96mm Turbine Wheel
171698	1.32		
14961016101	1.45		
14961016100	1.58		

COMPRESSOR MAPS

S400SX-E 650 - 1350 HP Part #: 14009097010

Comp. Wheel Inducer Dia. (mm) 80.30
Comp. Wheel Outer Dia. (mm) 110.00

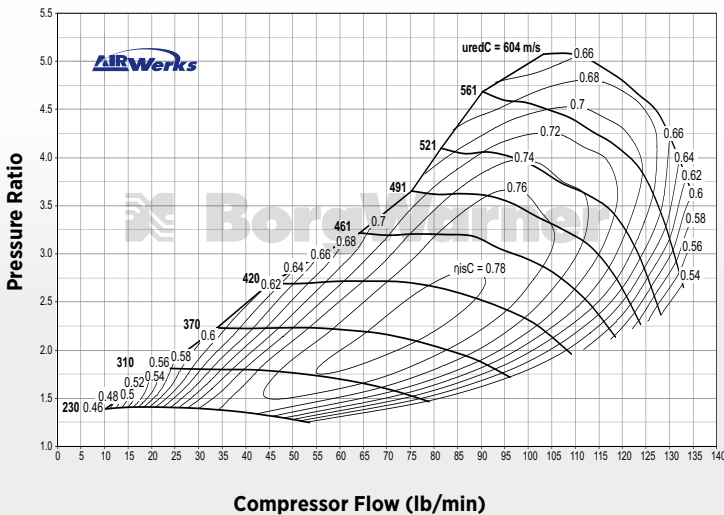

S400SX-E 750 - 1575 HP Part #: 14009097008

Comp. Wheel Inducer Dia. (mm) 87.93
Comp. Wheel Outer Dia. (mm) 110.00

