

S300SX3

320 - 800 HP Turbo



FEATURES

- Twin hydrodynamic journal bearings
- Extended tip technology compressor wheel
- Twin scroll turbine housing options available
- Adjustable compressor and turbine housing orientation
- Compressor cover recirculation grooves



TURBO FRAME DIMENSIONS

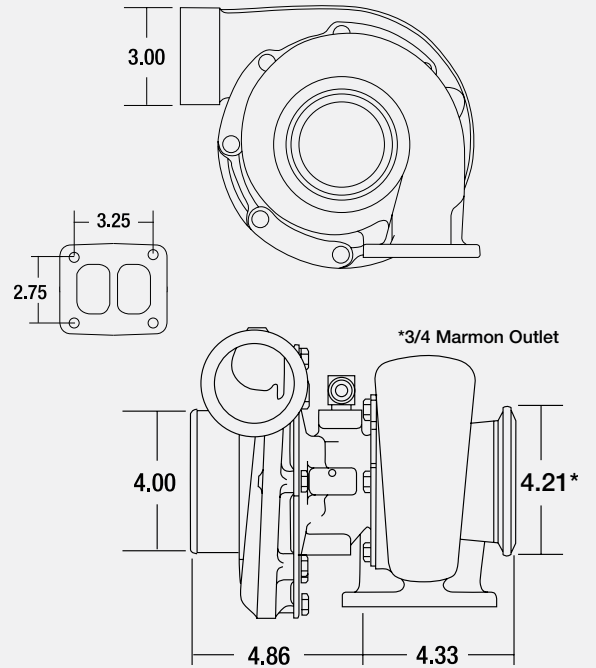

Turbo Part #	Comp. Wheel O.D. (in)	Comp Wheel O.D. (mm)	Comp Wheel Inducer Dia.	Comp Wheel Inducer Dia. (mm)	Turbine Wheel O.D. (in)	Turbine Wheel O.D. (mm)	Turbine Wheel Exducer (in)	Turbine Wheel Exducer (mm)	Turbine Housing A/R	Cartridge Assembly	Service Kit (Standard)	Service Kit (360° thrust bearing)
177281	3.60	91.44	2.60	66.11	3.14	79.76	2.89	73.37	0.88	176634	318393	13007110005
177275	3.60	91.44	2.60	66.11	3.14	79.76	2.89	73.37	0.91	176646	318393	13007110005
177272	3.29	83.47	2.36	60.03	3.00	76.20	2.66	67.56	0.91	176635	318393	13007110005

COMPRESSOR MAP / APPLICABLE TO PART NUMBER 177281 & 177275

Comp. Wheel Inducer Dia. (mm) 66.11
Comp. Wheel Outer Dia. (mm) 91.44

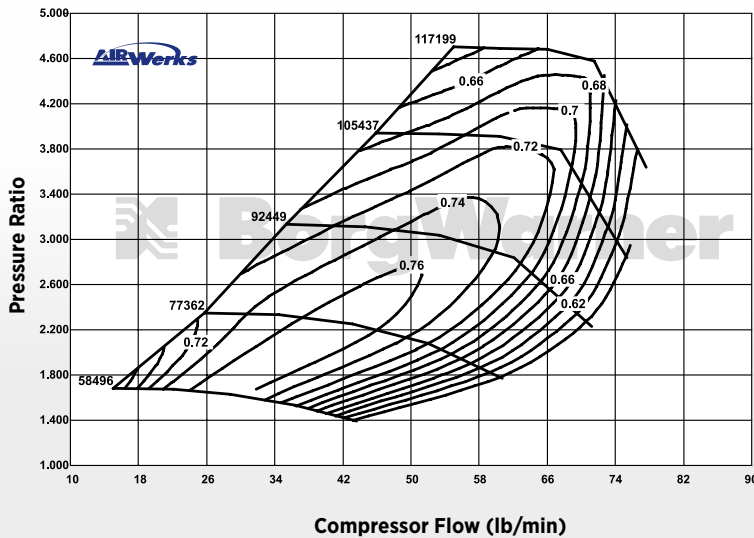

TURBINE HOUSING

Part #	A/R	Inlet Configuration	Notes
177211	0.88	Volute, Open Flow	80mm Turbine Wheel
177208	0.91	Volute, Twin Flow	
179905	1.00	Volute, Twin Flow	
177210	0.88	Volute, Open Flow	76mm Turbine Wheel
177207	0.91	Volute, Twin Flow	
177209	1.00	Volute, Twin Flow	

S300SX3

320 - 800 HP Turbo



FEATURES

- Twin hydrodynamic journal bearings
- Extended tip technology compressor wheel
- Twin scroll turbine housing options available
- Adjustable compressor and turbine housing orientation
- Compressor cover recirculation grooves



TURBO FRAME DIMENSIONS

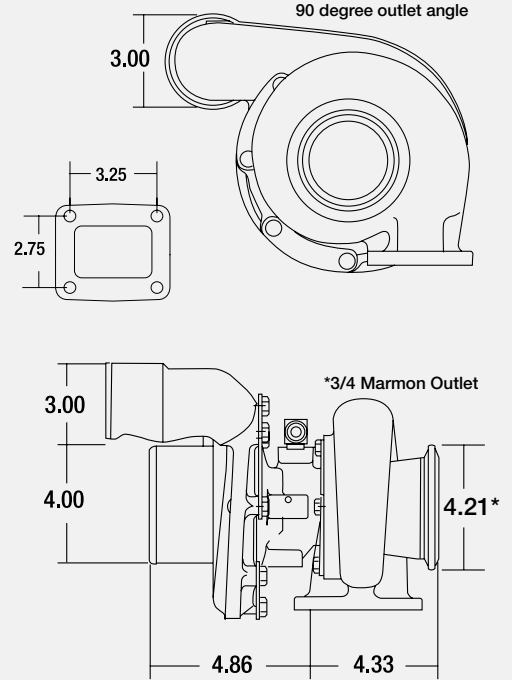

Turbo Part #	Comp. Wheel O.D. (in)	Comp Wheel O.D. (mm)	Comp Wheel Inducer Dia. (in)	Comp Wheel Inducer Dia. (mm)	Turbine Wheel O.D. (in)	Turbine Wheel O.D. (mm)	Turbine Wheel Exducer (in)	Turbine Wheel Exducer (mm)	Turbine Housing A/R	Cartridge Assembly	Service Kit (Standard)	Service Kit (360° thrust bearing)
177280	3.29	83.47	2.36	60.03	3.00	76.20	2.66	67.56	0.88	171901	318393	13007110005
177283	3.44	87.37	2.48	62.99	3.00	76.20	2.66	67.56	0.88	176648	318393	13007110005
177284	3.60	91.44	2.60	66.11	3.14	79.76	2.89	73.37	0.91	176650	318393	13007110005

COMPRESSOR MAP / APPLICABLE TO PART NUMBER 177283

Comp. Wheel Inducer Dia. (mm) 62.99
Comp. Wheel Outer Dia. (mm) 87.37

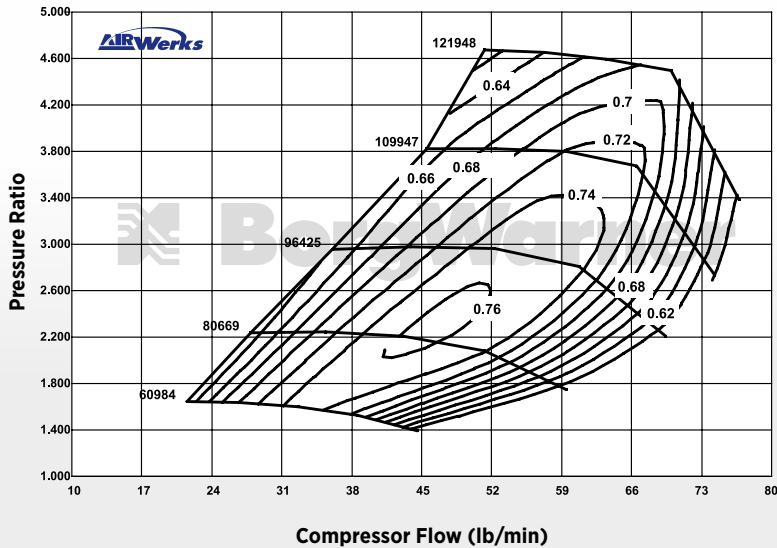

TURBINE HOUSING

Part #	A/R	Inlet Configuration	Notes
177211	0.88	Volute, Open Flow	T4 Inlet 80mm Turbine Wheel
177208	0.91	Volute, Twin Flow	
179905	1.00	Volute, Twin Flow	
177210	0.88	Volute, Open Flow	T4 Inlet 76mm Turbine Wheel
177207	0.91	Volute, Twin Flow	
177209	1.00	Volute, Twin Flow	