

S200SX-E

300 - 650 HP Super-Core



FEATURES

- Integrated speed sensor port
- Forged milled compressor wheel
- Pre-machined boost port
- Optimized compressor stage aerodynamics



Not included with turbo assemblies: Speed sensor, Turbine outlet V-Band, Drain port fitting

SUPER-CORE FRAME DIMENSIONS

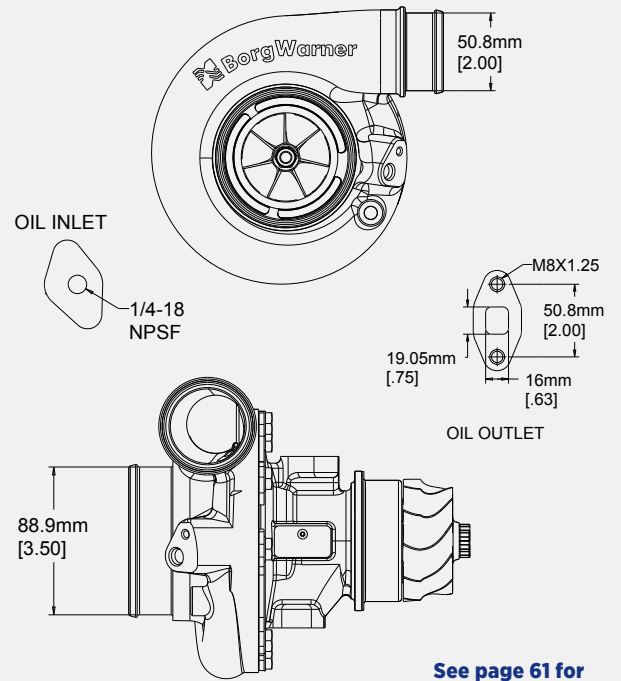

See page 61 for speed sensor details

Super-Core Part #	Comp. Wheel O.D. (in)	Comp. Wheel O.D. (mm)	Comp Wheel Inducer Dia. (in)	Comp Wheel Inducer Dia. (mm)	Turbine Wheel O.D. (in)	Turbine Wheel O.D. (mm)	Turbine Wheel Exducer (in)	Turbine Wheel Exducer (mm)	Service Kit
12709095019	2.74	69.60	2.05	52.17	2.74	69.56	2.42	61.43	318383
12769095003	3.00	76.20	2.25	57.15	2.74	69.56	2.42	61.43	318383

TURBINE HOUSING

Part #	A/R	Inlet Configuration	Notes
177191	0.83	Volute, Twin Flow T3 Volute Opening	70mm Turbine Wheel
177193	1.00		
177196	1.09		
177192	1.15		
177194	1.22		
178331	1.27		

All turbine housing mounting hardware, clamp plates and cap screws are included with Super-Core.

COMPRESSOR MAP / APPLICABLE TO PART NUMBER 313296

S200SX-E 300 - 550 HP Super-Core Part #: 12709095019

Comp. Wheel Inducer Dia. (mm) 52.17
Comp. Wheel Outer Dia. (mm) 69.60

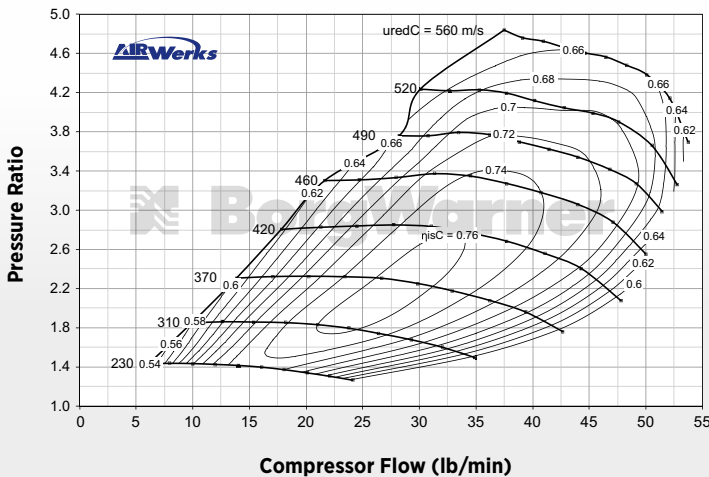

S200SX-E 300 - 650 HP Super-Core Part #: 12769095003

Comp. Wheel Inducer Dia. (mm) 57.15
Comp. Wheel Outer Dia. (mm) 76.20

