

Compact Torque Vectoring Technology opens up new Possibilities



Knowledge Library

Compact Torque Vectoring Technology opens up new Possibilities

BorgWarner's new drivetrain solution offers numerous benefits for OEMs and drivers.

By John Barlage, Director of Product Strategy, BorgWarner PowerDrive Systems

Introduction

The use of differential gears has been one of the fundamentals of vehicle handling almost since the birth of the automobile because they allow driven wheels to adjust their relative speeds during cornering. As a supplier of numerous drivetrain solutions, BorgWarner has always been at the forefront of developments with advanced technologies such as all-wheel drive (AWD) systems, electronic limited-slip differentials, hybrid electric drivelines and torque vectoring systems. Compact torque vectoring (CTV), the company's latest product, which can be seen in Figure 1, builds on its proven expertise in on-demand AWD applications and offers the next step forward in efficient drivetrain solutions. Due to the ever-increasing demand for AWD solutions across all vehicle segments, BorgWarner has developed a number of innovative technologies such as the highly successful AWD coupling, which automatically distributes torque from the primary driven axle to the second axle when required. BorgWarner's CTV technology takes this know-how to a whole new level. Offering a more progressive approach to tracking stability and safety as compared with systems like the electronic stability control (ESC), CTV induces a yaw moment into a cornering vehicle. Unlike other advanced driving assistance systems

such as ESC, which applies the brakes when it detects loss of steering control, CTV changes the torque distribution between the left- and right-hand wheels to pre-emptively improve handling and safety. Considerably faster cornering as compared to brake-based systems such as ESC is the result of using BorgWarner's CTV technology.

Changes of differential drive torque for enhanced stability

Used to improve the consistency of steering wheel input versus yaw rate, controlled changes to the torque distribution between the wheels on the left- and right-hand side enhance the vehicle dynamics and the response. While the total drive torque remains the same, the vehicle dynamics software



Figure 1. BorgWarner's compact torque vectoring (CTV) technology facilitates improved handling, stability and vehicle dynamics.

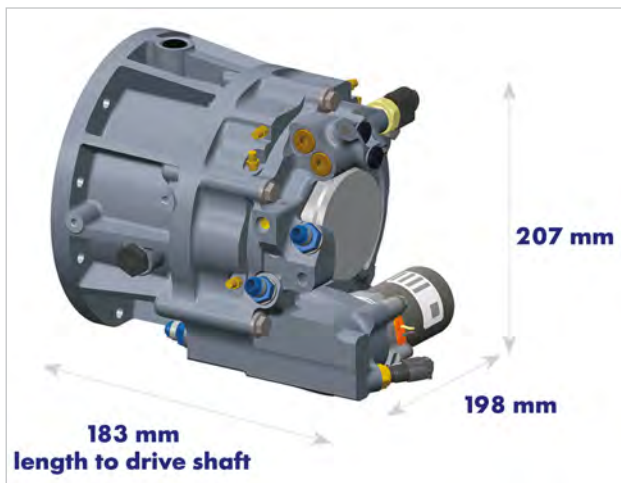

Figure 2. The CTV unit is considerably lighter than existing series solutions and features a net weight of just 13 kg, a length of 183 mm to the drive shaft, a height of 207 mm and a width of 198 mm.

determines the amount of differential drive torque using input from different sensors for yaw rate, lateral acceleration, wheel speed and steering angle.

BorgWarner's demonstration vehicle features a standard front-to-rear AWD coupling and a modified rear differential with the CTV unit mounted on the left-hand side of the differential. The CTV unit consists of two sun gears and twelve planet gears. Transmitting torque between the differential case and the left drive shaft, pairs of 19-tooth and 21-tooth planet gears operate on six concentric shafts surrounding the two 76-tooth sun gears. When triggered by a reversible centrifugal electro-hydraulic (CEH) actuator based on the proven AWD coupling technology, torque can be transferred between the 19-tooth wheel and the 21-tooth wheel by applying clamping force to a small wet clutch located at the end of each planet shaft. The CTV is inactive and the rear drive unit works in the traditional manner if no clamping force is applied. The clutch clamping force is obtained via annular hydraulic pistons located on each clutch. By controll-

ing the hydraulic pressure, it is possible to obtain the required torque vectoring effect. An additional drive torque is transferred to the left-hand rear wheel to increase its speed by simultaneously applying force to the clutches of three of the shafts. Correspondingly, the speed and torque at the right-hand rear wheel are reduced, and the resulting yaw moment causes the vehicle to veer right. Alternatively, by pressurising the other three clutches that slow down the left hand side wheel, its torque and speed decrease, the differential automatically increases the torque and the wheel speed on the right-hand side, and the resulting yaw moment causes the vehicle to veer left. While the vehicle is running straight ahead, no hydraulic pressure is applied, so there is no clutch activity.

Increased vehicle dynamics, safety and versatile production

OEMs benefit especially from the CTV's compact size, its low weight and versatility. With a net weight of just 13 kg, a length of 183 mm to the driveshaft, a height of 207 mm and a width of 198 mm, the CTV unit, as displayed in Figure 2, is considerably lighter than existing series solutions. Additionally, its location at the side of the differential unit and its compact dimensions help with vehicle packaging. Carryover axle components can be used for reduced system cost since the torque vectoring components are packaged on one side of the axle differential. The modular design, as shown in Figure 3, allows low-impact platform integration, and this facilitates the use of the units in applications across different vehicle platforms. Another advantage is that the CTV components can equally be applied to AWD systems based on rear-wheel and front-wheel drive. As a simple

“bolt-on” unit on the rear differential, CTV can allow the same base vehicle or platform to be offered with or without optional torque vectoring.



Figure 3. Low-impact platform integration is enabled due to the system’s modular design, facilitating the use of the units in applications across different vehicle platforms and models.

Moreover, direct actuation using the proven reversible CEH actuator is less sensitive to contamination and more robust than systems comprising control valves. The flow is directed in two directions, thus eliminating the need for an additional valve. While allowing easy pressure sensing and detection by the pressure sensor, hydraulic actuation also provides excellent torque accuracy and low hysteresis.

BorgWarner’s new technology also offers numerous benefits for the driver. Compact torque vectoring helps to improve handling, stability and vehicle dynamics across all vehicle sectors. Enhancing vehicle dynamics and safety significantly by distributing additional torque in fractions of a second, the system features a torque vectoring capacity of up to 1000 Nm. This technology controls the torque distribution in critical driving situations such as accelerating and steering into a corner and provides smoother steering responses as well as considerably less steering input compared to similar cars without torque vectoring. As a result, it offers superior vehicle handling, particularly on slippery road surfaces.

Contact

Email: technology@borgwarner.com
For more information please visit
borgwarner.com